

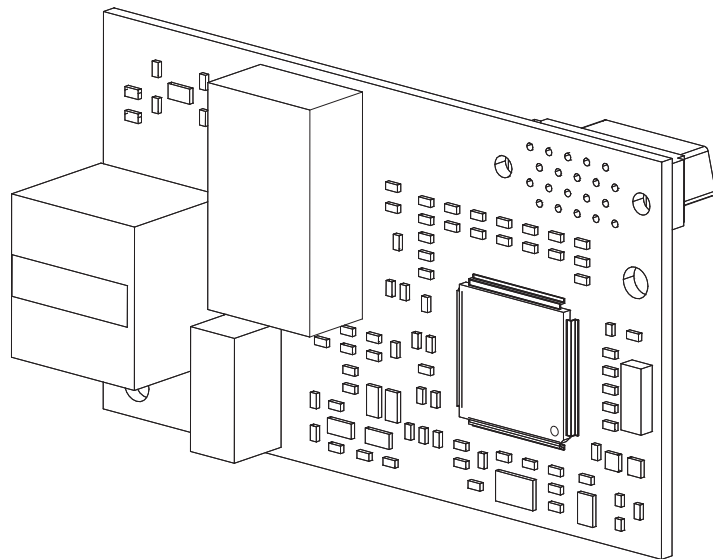

# YASKAWA AC Drive 1000-Series Option **Modbus TCP/IP** **Technical Manual**

Type SI-EM3

To properly use the product, read this manual thoroughly and retain for easy reference, inspection, and maintenance. Ensure the end user receives this manual.



---

Copyright © 2009 YASKAWA ELECTRIC AMERICA

All rights reserved. No part of this publication may be reproduced, stored in a retrieval system, or transmitted, in any form or by any means, mechanical, electronic, photocopying, recording, or otherwise, without the prior written permission of Yaskawa. No patent liability is assumed with respect to the use of the information contained herein. Moreover, because Yaskawa is constantly striving to improve its high-quality products, the information contained in this manual is subject to change without notice. Every precaution has been taken in the preparation of this manual. Yaskawa assumes no responsibility for errors or omissions. Neither is any liability assumed for damages resulting from the use of the information contained in this publication.



# Table of Contents

---

1	PREFACE AND SAFETY .....	4
2	PRODUCT OVERVIEW .....	7
3	RECEIVING .....	8
4	OPTION COMPONENTS .....	9
5	INSTALLATION PROCEDURE .....	11
6	OPTION DRIVE PARAMETERS .....	18
7	MODBUS TCP/IP MESSAGING .....	20
8	WEB INTERFACE .....	30
9	TROUBLESHOOTING .....	34
10	SPECIFICATIONS .....	38

# 1 Preface and Safety

Yaskawa manufactures products used as components in a wide variety of industrial systems and equipment. The selection and application of Yaskawa products remain the responsibility of the equipment manufacturer or end user. Yaskawa accepts no responsibility for the way its products are incorporated into the final system design. Under no circumstances should any Yaskawa product be incorporated into any product or design as the exclusive or sole safety control. Without exception, all controls should be designed to detect faults dynamically and fail safely under all circumstances. All systems or equipment designed to incorporate a product manufactured by Yaskawa must be supplied to the end user with appropriate warnings and instructions as to the safe use and operation of that part. Any warnings provided by Yaskawa must be promptly provided to the end user. Yaskawa offers an express warranty only as to the quality of its products in conforming to standards and specifications published in the Yaskawa manual. **NO OTHER WARRANTY, EXPRESSED OR IMPLIED, IS OFFERED.** Yaskawa assumes no liability for any personal injury, property damage, losses, or claims arising from misapplication of its products.

### ◆ Applicable Documentation

The following manuals are available for the SI-EM3 option:

#### SI-EM3 Option

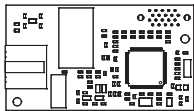
	<b>Yaskawa AC Drive -SI-EM3 Modbus TCP/IP Option Installation Manual</b> <b>Manual No: TOEP YEACOM 05□</b>
	Read this manual first. The installation manual is packaged with the SI-EM3 option and contains a basic overview of wiring, settings, functions, and fault diagnoses.
	<b>Yaskawa AC Drive -SI-EM3 Modbus TCP/IP Option Technical Manual</b> <b>Manual No: SIEP YEACOM 05□</b>
	The technical manual contains detailed information. To obtain the technical manual access these sites: U.S.: <a href="http://www.yaskawa.com">http://www.yaskawa.com</a> Other areas: contact a Yaskawa representative.

#### Yaskawa Drive

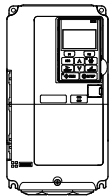
	Refer to the manual of the drive this option is being used with. The instruction manual for the drive covers basic installation, wiring, operation procedures, functions, troubleshooting, and maintenance information. It also includes important information on parameter settings and how to tune the drive. A Quick Start Guide is included with the drive. For the more detailed Technical Manual, visit Yaskawa's homepage.  U.S.: <a href="http://www.yaskawa.com">http://www.yaskawa.com</a> Other areas: contact a Yaskawa representative
---	--

### ◆ Terms

- Option:** Yaskawa AC Drive-Modbus TCP/IP SI-EM3 option.  
**Note:** Indicates supplemental information that is not related to safety messages.

### ◆ Registered Trademarks

- Modbus TCP/IP is a trademark of Modbus-IDA.
- All trademarks are the property of their respective owners.

## ◆ Supplemental Safety Information

Read and understand this manual before installing, operating, or servicing this option. The option must be installed according to this manual and local codes.

The following conventions are used to indicate safety messages in this manual. Failure to heed these messages could result in serious or possibly even fatal injury or damage to the products or to related equipment and systems.

### DANGER

Indicates a hazardous situation, which, if not avoided, will result in death or serious injury.

### WARNING

Indicates a hazardous situation, which, if not avoided, could result in death or serious injury.

### CAUTION

Indicates a hazardous situation, which, if not avoided, could result in minor or moderate injury.

### NOTICE

Indicates an equipment damage message.

## ■ General Safety

### General Precautions

- The diagrams in this section may include options and drives without covers or safety shields to illustrate details. Be sure to reinstall covers or shields before operating any devices. The option should be used according to the instructions described in this manual.
- Any illustrations, photographs, or examples used in this manual are provided as examples only and may not apply to all products to which this manual is applicable.
- The products and specifications described in this manual or the content and presentation of the manual may be changed without notice to improve the product and/or the manual.
- When ordering a new copy of the manual due to damage or loss, contact your Yaskawa representative or the nearest Yaskawa sales office and provide the manual number shown on the front cover.

### DANGER

**Heed the safety messages in this manual.**

Failure to comply will result in death or serious injury.

The operating company is responsible for any injuries or equipment damage resulting from failure to heed the warnings in this manual.

### NOTICE

**Do not expose the drive to halogen group disinfectants.**

Failure to comply may cause damage to the electrical components in the option.

Do not pack the drive in wooden materials that have been fumigated or sterilized.

Do not sterilize the entire package after the product is packed.

**Do not modify the drive circuitry.**

Failure to comply could result in damage to the drive and will void warranty.

Yaskawa is not responsible for any modification of the product made by the user. This product must not be modified.

## 2 Product Overview

### ◆ About This Product

The SI-EM3 option provides a communications connection between the drive and an Modbus TCP/IP network. The SI-EM3 option connects the drive to an Modbus TCP/IP network and facilitates the exchange of data.

This manual explains the handling, installation and specifications of this product.

Modbus TCP/IP is a communications link to connect industrial devices (such as smart motor controllers, operator interfaces, and variable frequency drives) as well as control devices (such as programmable controllers and computers) to a network. Modbus TCP/IP is a simple, networking solution that reduces the cost and time to wire and install factory automation devices, while providing interchangeability of like components from multiple vendors.

Modbus TCP/IP is an open device network standard.

By installing the SI-EM3 option to a drive, it is possible to do the following from a Modbus TCP/IP master device:

- operate the drive
- monitor the operation status of the drive
- change parameter settings.

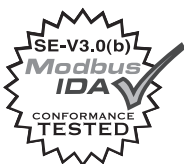

### ◆ Applicable Models

The SI-EM3 option can be used with the drive models in [Table 1](#).

**Table 1 Applicable Models**

Voltage Class	Drive	Software Version <1>
200 V	CIMR-AU2A0004 ~ CIMR-AU2A0415	VSA90101□
400 V	CIMR-AU4A0002 ~ CIMR-AU4A1200	
600 V	CIMR-AU5A0002 ~ CIMR-AU5A0242	VSA90504□





<1> See “PRG” on the drive nameplate for the software version number.

## 3 Receiving

Please perform the following tasks upon receipt of the option:

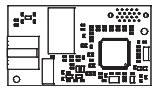
- Inspect the option for damage. Contact the shipper immediately if the option appears damaged upon receipt.
- Verify receipt of the correct model by checking the model number printed on the name plate of the option package.
- Contact your supplier if you have received the wrong model or the option does not function properly.

### ◆ Option Package Components

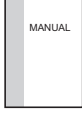
Description:	Option PCB	Ground Wire	Screws (M3)	LED Label	Installation Manual
-					
Quantity:	1	1	3	1	1

### ◆ Tools Required for Installation

- A Phillips screwdriver (M3 metric/#1, #2 U.S. standard size\*) is required to install the option and remove drive front covers.
- Diagonal cutting pliers. (required for some drive models)
- A small file or medium grit sandpaper. (required for some drive models)

\*Screw sizes vary by drive capacity. Select a screwdriver appropriate for the drive capacity.

**Note:** Tools required to prepare option networking cables for wiring are not listed in this manual.



## 4 Option Components

### ◆ SI-EM3 Modbus TCP/IP Option

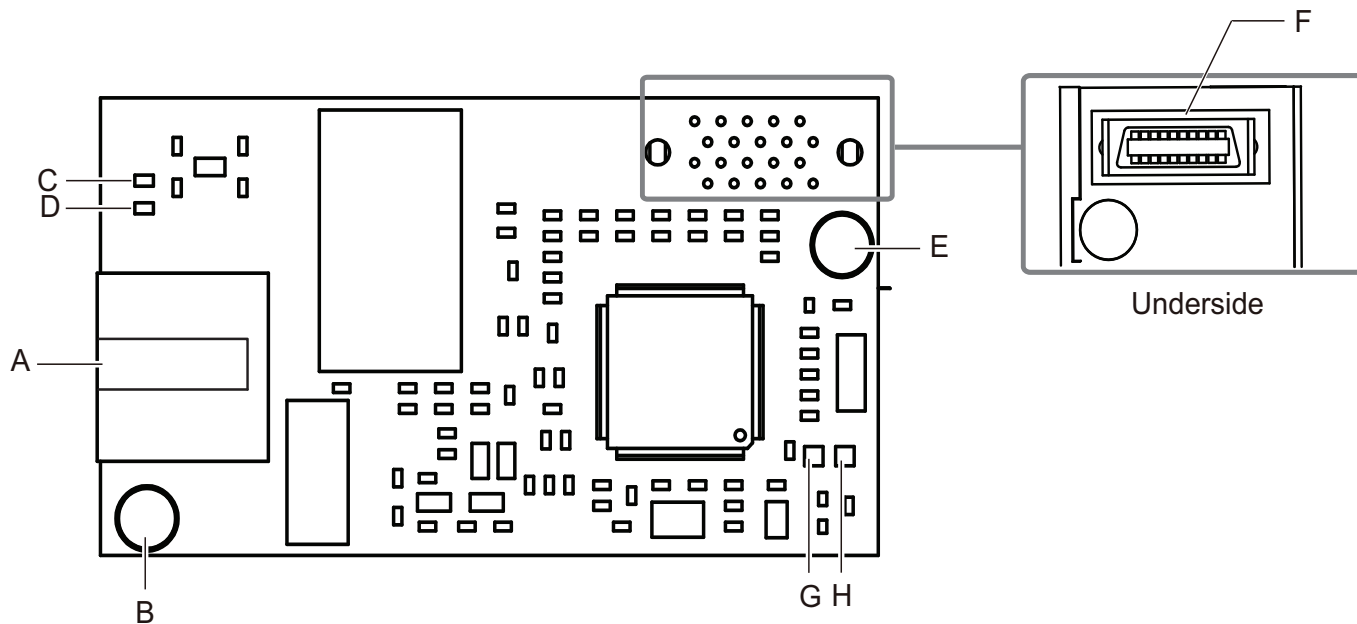

A – Modbus TCP/IP Modular Female Connector (CN1)

B – Ground Terminal and installation hole

C – LED (10/100)

D – LED (LINK/ACT)

E – Installation hole

F – Connector (CN5)

G – LED (NS)

H – LED (MS)

<1> The ground wire provided in the option shipping package must be connected during installation

<2> Refer to [Option LED Display on page 10](#) for details on the LEDs

Figure 1 Option (Top View)

### ◆ Terminal CN1

The communication connector on the SI-EM3 option is a modular RJ45 female connector designated CN1. CN1 is the connection point for a customer supplied male Modbus network communication cable.

Table 2 Male, 8-way Ethernet Modular Connector (Customer Supplied)

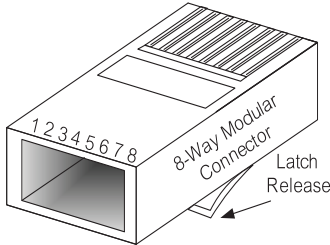
Male Ethernet 8-Way Modular Connector	Pin	Description
	1 (Pair 2)	Transmit data (TXD) +
	2 (Pair 2)	Transmit data (TXD) -
	3 (Pair 3)	Receive data (RXD) +
	4 (Pair 1)	Not used <1>
	5 (Pair 1)	Not used <1>
	6 (Pair 3)	Receive data (RXD) -
	7 (Pair 4)	Not used <1>
	8 (Pair 4)	Not used <1>

<1> Not used for 10 Mbps and 100 Mbps networks.

## 4 Option Components

### ◆ Option LED Display

The option has four LEDs:

#### Bi-color Status LEDs:

- Module status (MS) red/green
- Network status (NS) red/green

#### Green Ethernet LEDs:

- Network speed-10/100 (MS) green
- Link status and network activity-Link/Act (NS) red/green

The operational states of the option LEDs after the power-up diagnostic LED sequence is completed are described in [Table 3](#). Wait at least 2 seconds for the power-up diagnostic process to complete before verifying the states of the LEDs.

**Table 3 Option LED States**

Name	Indication		Operating Status	Remarks
	Color	Status		
<b>MS</b> (visible thru drive cover)	–	OFF	Power supply OFF	Power is not being supplied to the drive
	Green	ON	Option operating	The option is operating normally
	Green	Flashing	Option initializing	The option is configuring an IP address
	Red	ON	Fatal error occurred	The option has detected a fatal (unrecoverable) error
	Red	Flashing	Non-fatal error occurred	The option has detected a non-fatal (recoverable) error Example: Loss of link fault
<b>NS</b> (visible thru drive cover)	–	OFF	Offline or Power supply OFF	–
	Green	ON	Online communications established	The option is online and has established connections
	Green	Flashing	Online communications not established	The option is online and has an established connection
	Red	ON	Communications error (fatal)	The option detected a duplicate IP address or a control connection has timed out

**Table 4 Option LEDs**

Name	Indication		Operating Status
	Color	Status	
<b>10/100</b> (visible with front cover removed)	Green	OFF	10 Mbps is established
	Green	ON	100 Mbps is established
<b>LINK/ACT</b> (visible with front cover removed)	Green	OFF	Link is not established
	Green	ON	Link is established
	Green	Flashing	Link is established and there is network activity

## 5 Installation Procedure

### ◆ Section Safety

#### DANGER

##### Electrical Shock Hazard

**Do not connect or disconnect wiring while the power is on.**

Failure to comply will result in death or serious injury.

Disconnect all power to the drive, wait at least five minutes after all indicators are off, measure the DC bus voltage to confirm safe level, and check for unsafe voltages before servicing to prevent electric shock. The internal capacitor remains charged even after the power supply is turned off. The charge indicator LED will extinguish when the DC bus voltage is below 50 Vdc.

#### WARNING

##### Electrical Shock Hazard

**Do not remove the front cover of the drive while the power is on.**

Failure to comply could result in death or serious injury.

The diagrams in this section may include options and drives without covers or safety shields to show details. Be sure to reinstall covers or shields before operating any devices. The option should be used according to the instructions described in this manual.

**Do not allow unqualified personnel to use equipment.**

Failure to comply could result in death or serious injury.

Maintenance, inspection, and replacement of parts must be performed only by authorized personnel familiar with installation, adjustment, and maintenance of this product.

**Do not touch circuit boards while the power to the drive is on.**

Failure to comply could result in death or serious injury.

**Do not use damaged wires, place excessive stress on wiring, or damage the wire insulation.**

Failure to comply could result in death or serious injury.

##### Fire Hazard

**Tighten all terminal screws to the specified tightening torque.**

Loose electrical connections could result in death or serious injury by fire due to overheating of electrical connections.

#### NOTICE

##### Damage to Equipment

**Observe proper electrostatic discharge (ESD) procedures when handling the option, drive, and circuit boards.**

Failure to comply may result in ESD damage to circuitry.

**Never shut the power off while the drive is outputting voltage.**

Failure to comply may cause the application to operate incorrectly or damage the drive.

### NOTICE

**Do not operate damaged equipment.**

Failure to comply may cause further damage to the equipment.

Do not connect or operate any equipment with visible damage or missing parts.

**Do not use unshielded cable for control wiring.**

Failure to comply may cause electrical interference resulting in poor system performance.

Use shielded twisted-pair wires and ground the shield to the ground terminal of the drive.

**Properly connect all pins and connectors.**

Failure to comply may prevent proper operation and possibly damage equipment.

**Check wiring to ensure that all connections are correct after installing the option and connecting any other devices.**

Failure to comply may result in damage to the option.

## ◆ Prior to Installing the Option

Prior to installing the option, wire the drive and make necessary connections to the drive terminals. Refer to the drive Quick Start Guide for information on wiring and connecting the drive. First, verify that the drive functions normally without the option installed.

*Figure 2* shows an exploded view of the drive with the option and related components for reference.

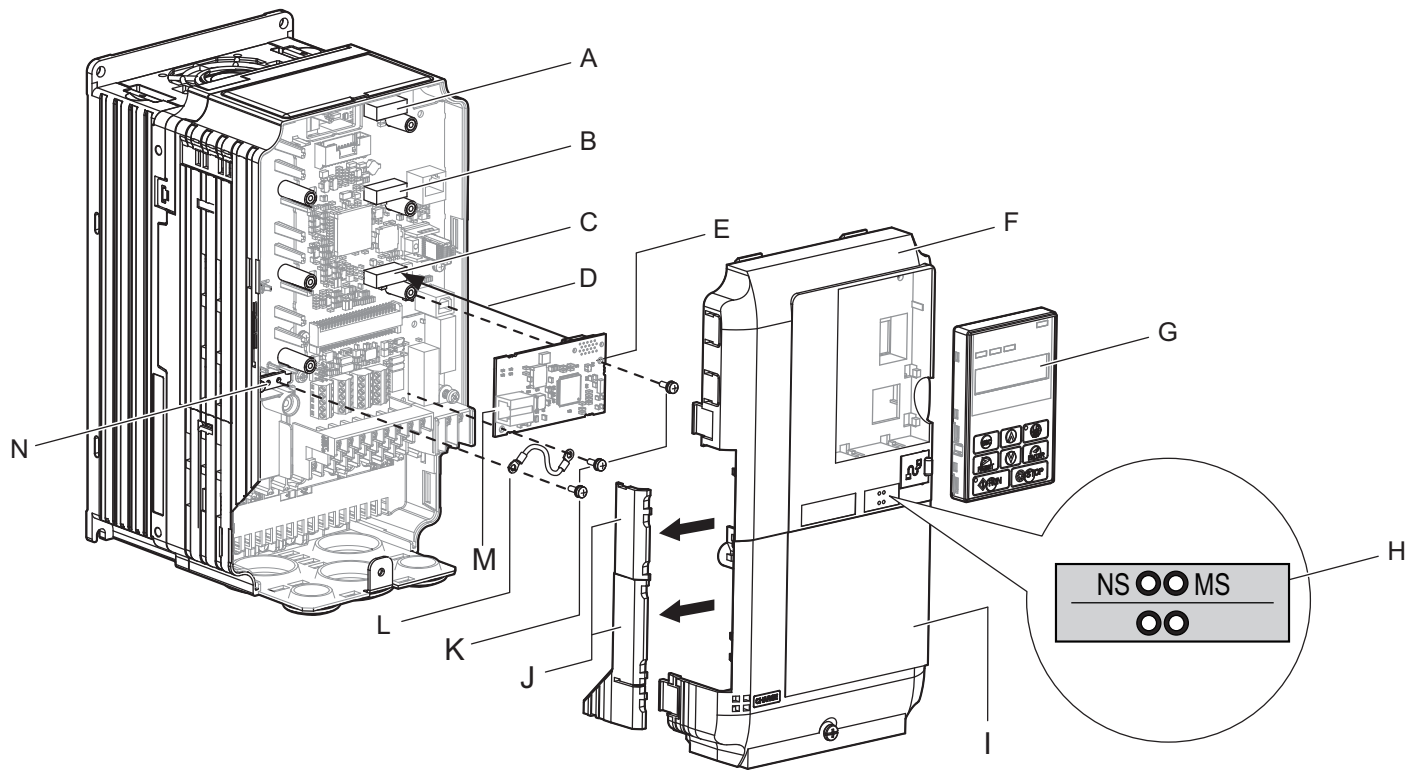

- |  |  |
|--|--|
| <b>A</b> – Connector CN5-C                   | <b>H</b> – LED label                       |
| <b>B</b> – Connector CN5-B                   | <b>I</b> – Drive terminal cover            |
| <b>C</b> – Connector CN5-A                   | <b>J</b> – Removable tabs for wire routing |
| <b>D</b> – Insertion point for CN5 connector | <b>K</b> – Included screws                 |
| <b>E</b> – SI-EM3 option                     | <b>L</b> – Ground wire                     |
| <b>F</b> – Drive front cover                 | <b>M</b> – Option modular connector CN1    |
| <b>G</b> – Digital operator                  | <b>N</b> – Drive grounding terminal (FE)   |

Figure 2 Drive Components with Option

### ◆ Installing the Option

Remove the front covers of the drive before installing the option. Refer to the drive Quick Start Guide for directions on removing the front covers. Cover removal varies depending on drive size. This option can be inserted only into the CN5-A connector located on the drive's control board.

1. Shut off power to the drive, wait the appropriate amount of time for voltage to dissipate, then remove the digital operator (G) and front covers (F, I). Front cover removal varies by model. Refer to the Quick Start Guide supplied with the drive for more information on front cover removal.

**DANGER!** *Electrical Shock Hazard. Do not connect or disconnect wiring while the power is on. Failure to comply will result in death or serious injury. Before installing the option, disconnect all power to the drive. The internal capacitor remains charged even after the power supply is turned off. The charge indicator LED will extinguish when the DC bus voltage is below 50 Vdc. To prevent electric shock, wait at least five minutes after all indicators are off and measure the DC bus voltage level to confirm safe level.*

**NOTICE:** *Damage to Equipment. Observe proper electrostatic discharge procedures (ESD) when handling the option, drive, and circuit boards. Failure to comply may result in ESD damage to circuitry.*

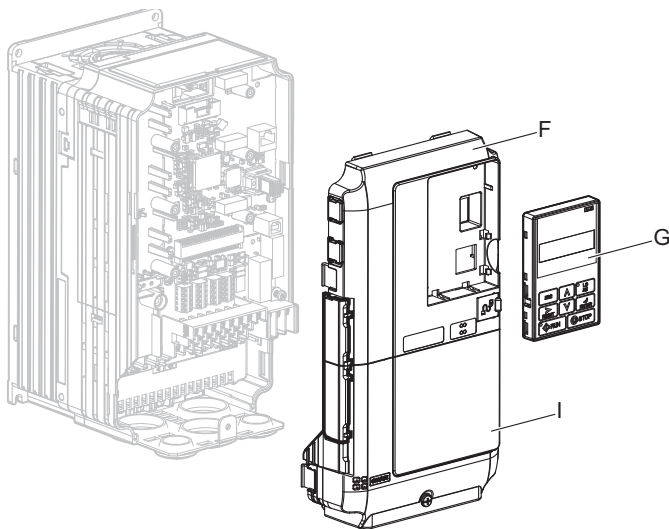

Figure 3 Remove the Front Covers and Digital Operator

2. With the front covers and digital operator removed, apply the LED label (H) in the appropriate position on the drive top front cover (F).

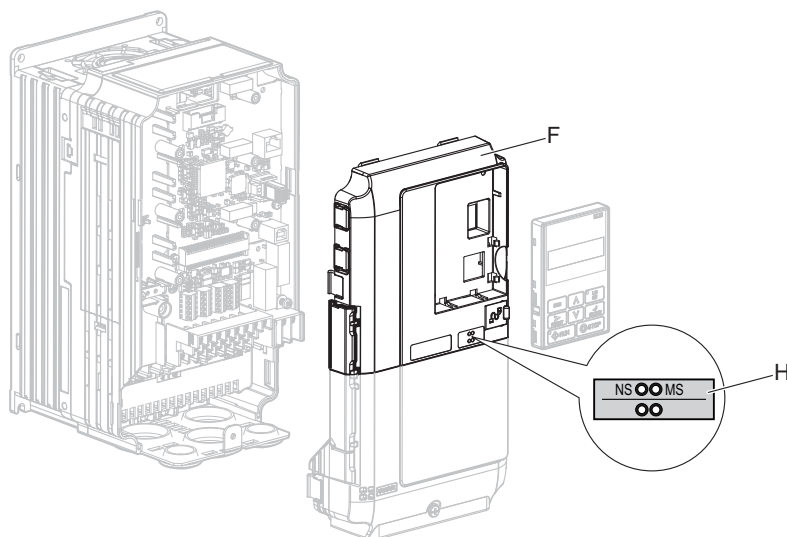
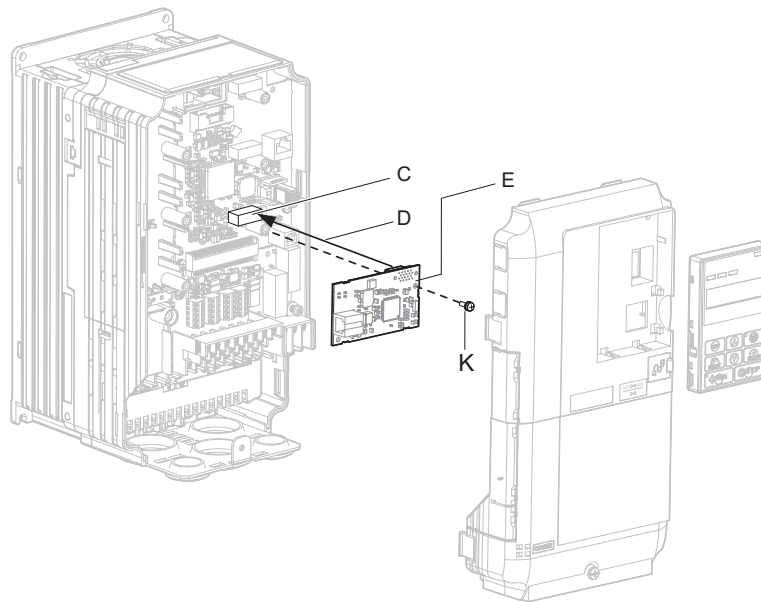

Figure 4 Apply the LED Label

3. Insert the option (E) into the **CN5-A** connector (C) located on the drive and fasten it using one of the included screws (K).



**Figure 5 Insert the Option**

4. Connect the ground wire (L) to the ground terminal (N) using one of the remaining provided screws (K). Connect the other end of the ground wire (L) to the remaining ground terminal and installation hole on the option (E) using the last remaining provided screw (K) and tighten both screws to 0.5 ~ 0.6 nm or (4.4 ~ 5.3 in lbs).

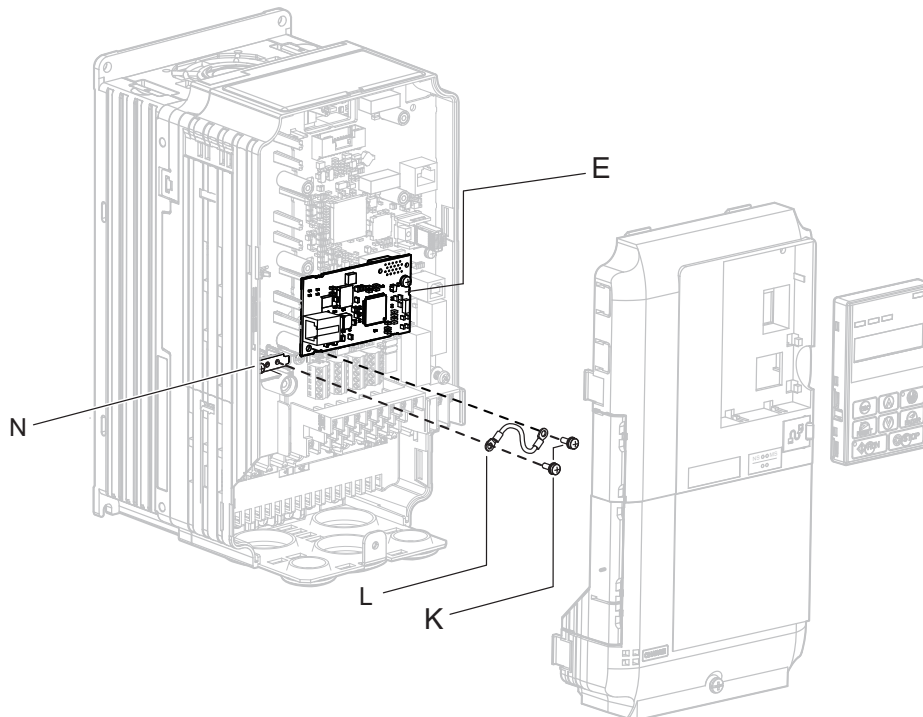

**Figure 6 Connect the Ground Wire**

**Note:** There are two screw holes on the drive for use as ground terminals. When connecting three options, two ground wires will need to share the same drive ground terminal.

## 5 Installation Procedure

### ■ Wiring the Option

#### 5. Route the option wiring.

Depending on the drive model, some drives may require routing the wiring through the side of the front cover to the outside to provide adequate space for the wiring. In these cases, using diagonal cutting pliers, cut out the perforated openings on the left side of the drive front cover. Sharp edges along the cut out should be smoothed down with a file or sand paper to prevent any damage to the wires.

**5.a** Route the Ethernet cable inside the enclosure for drives that do not require routing through the front cover. Refer to [Table 5](#) and [Figure 7](#) to determine the proper wire routing by drive model.

**Table 5 Model-Specific Cable Routing**

Drive Series	Model	Wire Routing <1>	
		Through Front Cover	Inside Drive
A1000	CIMR-A□2A0004 to 0040; CIMR-A□4A0002 to 0023; CIMR-A□5A0003 to 0011	<a href="#">Figure 7 (A)</a>	-
A1000	CIMR-A□2A0056 and above; CIMR-A□4A0031 and above; CIMR-A□5A0023 and above.	-	<a href="#">Figure 7 (B)</a>

<1> Refer to [Figure 7](#) for examples of the different wire routing techniques.

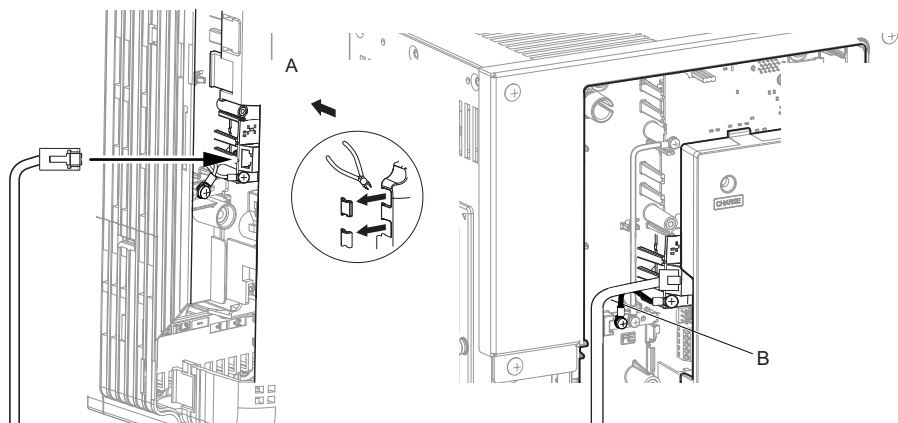

**A – Route wires through the openings provided on the left side of the front cover. <1>**

**B – Use the open space provided inside the drive to route option wiring.**

<1> The drive will not meet NEMA Type 1 requirements if wiring is exposed outside the enclosure.

**Figure 7 Wire Routing Examples**

#### 6. Connect the Ethernet communication cable to the option modular connector (CN1).

To connect the SI-EM3 option to a network, insert the RJ45 connector of the STP Cat 5e patch cable into the option modular connector (CN1). Ensure the cable end is firmly connected (see [Figure 7](#)).

### Communication Cable Specifications

Only use cable recommended for (Modbus TCP/IP™). Using a cable not specifically recommended may cause the SI-EM3 option or drive to malfunction.



## ■ Connection Diagram

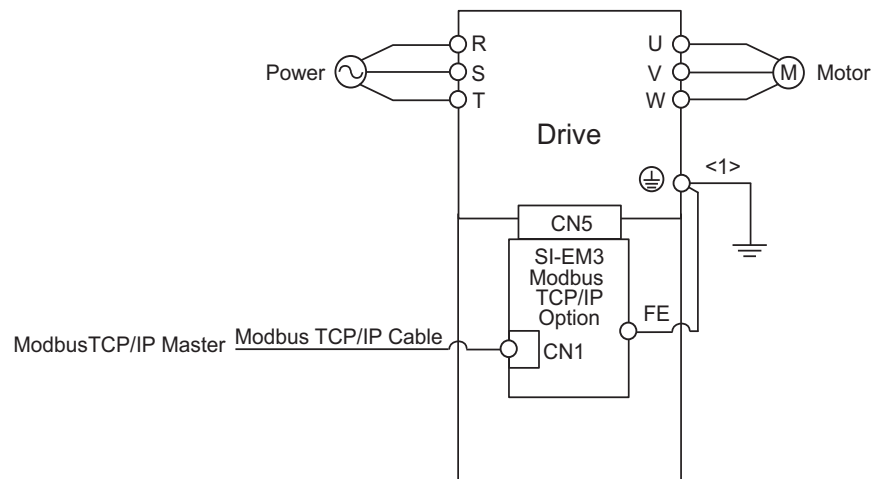

<1> The ground wire provided in the option shipping package must be connected during installation.

**Figure 8 Wiring Diagram**

7. Replace and secure the front covers of the drive (F, I) and replace the digital operator (G).

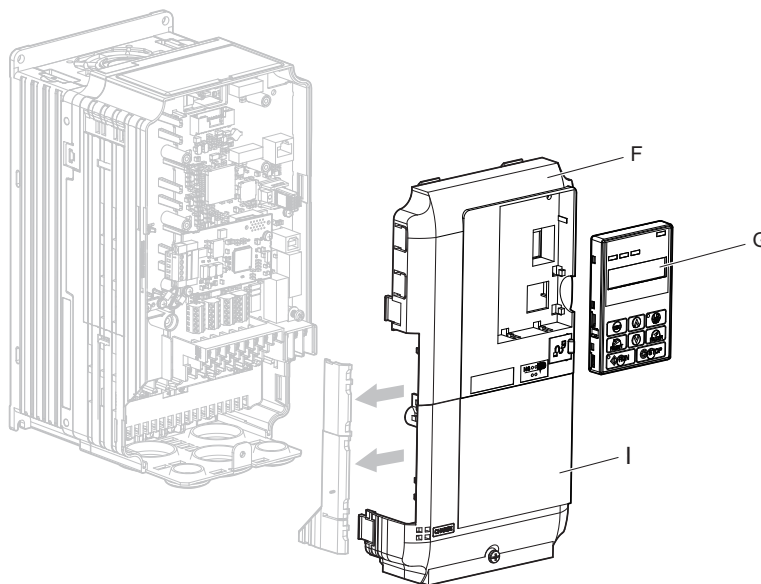

**Figure 9 Replace the Front Covers and Digital Operator**

**Note:** Take proper precautions when wiring the option so that the front covers will easily fit back onto the drive. Make sure no cables are pinched between the front covers and the drive when replacing the covers.

8. Set drive parameters in [Table 6](#) for proper option performance.

## 6 Option Drive Parameters

The following parameters are used to set up the drive for operation with the option. Parameter setting instructions can be found in the drive Quick Start Guide or Technical Manual.

Confirm proper setting of the all parameters in [Table 6](#) before starting network communications.

**Table 6 Related Parameter Settings**

No.	Name	Description	Default
b1-01 <1>	Frequency Reference Selection	Selects the frequency reference input source 0: Operator - Digital preset speed d1-01 to d1-17 1: Terminals - Analog input terminal A1 or A2 2: MEMOBUS/Modbus communications 3: Option PCB 4: Pulse Input (Terminal RP)	1 (Set to 3)
b1-02 <1>	Run Command Selection	Selects the run command input source 0: Digital Operator - RUN and STOP keys 1: Digital input terminals S1 to S□ 2: MEMOBUS/Modbus communications 3: Option PCB	1 (Set to 3)
F6-01	Operation Selection after Communications Error	Determines drive response when a bUS error is detected during communications with the SI-EM3 option 0: Ramp to Stop 1: Coast to Stop 2: Fast-Stop 3: Alarm Only <2>	1
F6-02	External Fault Detection Conditions (EF0)	Sets the condition for external fault detection (EF0) 0: Always detected 1: Detected only during operation	0
F6-03	Stopping Method for External Fault from the Communication Option	Determines drive response for external fault input (EF0) detection during option communications. 0: Ramp to Stop 1: Coast to Stop 2: Fast-Stop 3: Alarm Only <2>	1
F6-06 <3>	Torque Reference/Torque Limit Selection from the Communication Option	0: Torque Reference/Torque Limit via network communications are disabled. 1: Torque Reference/Torque Limit via network communications are enabled.<4>	0
F6-07	NetRef/ComRef Selection Function	0: Multi-step speed reference disabled, (F7 functionality) 1: Multi-step speed reference allowed (V7 functionality)	0
F6-08	Reset Communication Related Parameters	Determines if communication-related parameters F6-□□ and F7-□□ are set back to original default values when the drive is initialized using parameter A1-03 0: Do not reset parameters 1: Reset parameters	0
F7-01 to F7-04 <5>	IP Address	Sets static IP address of network connection Parameter F7-01 sets the most significant octet	192 168 1 20
F7-05 to F7-08	Subnet Mask	Sets static Subnet Mask of network connection Parameter F7-05 sets the most significant octet	255 255 255 0
F7-09 to F7-12	Gateway Address	Sets static Gateway address of network connection Parameter F7-09 sets the most significant octet	192 168 1 1
F7-13	Address Mode at Startup	Selects how the SI-EM3 address is set 0: Static <5> 1: BOOTP 2: DHCP	2
F7-14	Duplex Mode Selection	Selects duplex mode setting 0: Half duplex forced 1: Auto-negotiate duplex mode and communication speed 2: Full duplex forced	0

No.	Name	Description	Default
F7-15	Communication Speed Selection	Sets the communication speed 10: 10 Mbps 100: 100 Mbps	10
F7-16	Communication Loss Time-out	Sets the time-out value for communication loss detection. The value is in tenths of a second. Example: An entered value of 100 represents 10.0 seconds. A value of 0 disables the connection time-out.	0
H5-11	Communications ENTER Function Selection	Select the function for the ENTER command that saves parameter data to the drive. 0: Parameter changes are activated when ENTER command is written 1: Parameter changes are activated immediately without use of ENTER command	1

<1> To start and stop the drive with the option master device using serial communications, set b1-02 to “3”. To control the drive frequency reference via the master device, set b1-01 to “3”.

<2> If F6-01 is set to 3, then the drive will continue to operate when a fault is detected. Take proper safety measures, such as installing an emergency stop switch.

<3> Enabled in CLV, PM OLV 2, and PM CLV control modes (A1-02 = 3, 6, or 7). When enabled, d5-01 determines whether the value is read as the Torque Limit value (d5-01 = 0) or read as the Torque Reference value (d5-01 = 1). In Closed Loop Vector for PM motors, this value is read as the Torque Limit.

<4> Default setting specifies that the Torque Reference or Torque Limit is to be provided via network communications (F6-06 = 1). The motor may rotate if no torque reference or Torque Limit is supplied from the PLC.

<5> If F7-13 is set to 0, then all IP Addresses (F7-01 to F7-04) must be unique.

<6> Power must be cycled in order for any setting changes to take effect.

**Table 7 SI-EM3 Option Monitors**

No.	Name	Description	Value Range
U6-80 to U6-83	Online IP Address	IP Address; U6-80 is the most significant octet	0 to 255
U6-84 to U6-87	Online Subnet	Subnet; U6-84 is the most significant octet	0 to 255
U6-88 to U6-91	Online Gateway	Gateway; U6-88 is the most significant octet	0 to 255
U6-92	Online Speed	Link Speed	10, 100
U6-93	Online Duplex	Duplex Setting	0: Half, 1: Full
U6-98	First Fault	First Option Fault	-
U6-99	Current Fault	Current Option Fault	-

## 7 Modbus TCP/IP Messaging

### ◆ Modbus TCP/IP Overview

The Modbus TCP/IP protocol is basically the Modbus protocol over an Modbus TCP/IP network. As such, a master controller sends commands to slave devices. The slave, in turn, will perform the specified function and then send a response back to the master. Masters are typically a PLC. The drive using the SI-EM3 option has slave functionality.

### ■ Supported Modbus TCP/IP Commands

**Table 8 Supported Modbus TCP/IP Commands**

Function Code	Function Name
03H	Read Multiple Registers
06H	Write Single Register
10H	Write Multiple Registers
17H	Read/Write Multiple Registers

### ■ Drive Modbus TCP/IP Option Registers

All of the command registers, monitors registers and parameters documented in the Drive Technical Manual are accessible via the SI-EM3 Option.

### ■ High Speed Access Drive Modbus TCP/IP Option Registers

Many of the registers required for control have been specially mapped to provide higher speed access, which will increase network performance. It is recommended that these registers be used for best response times.

All of the drive command registers have been mapped to this high speed access area (Modbus TCP/IP registers 01H to 01FH). In addition, the monitors shown in [Table 9](#) are mapped for high speed access.

Table 9 Drive Registers

Address (hex)	Drive Register (hex)	Description	Bit	Description
2000	4B	Status Word (U1-12)	0	During Run
			1	During Zero Speed
			2	During Reverse Direction
			3	During Fault Reset Signal Input
			4	During Speed Agree
			5	Drive Ready
			6	Alarm
			7	Fault
			8	During Operation Error (OPE□□)
			9	During Momentary Power Loss
			A	Motor 2 Selected
			B	Reserved
			C	Reserved
			D	Reserved
			E	ComRef Status, NetRef Status
F	ComCtrl Status, NetCtrl Status			
2001	44	Motor Speed Monitor (U1-05)		
2002	48	Torque Reference Monitor (U1-09)		
2003	F0	PG Count Channel 1		
2004	40	Frequency Reference Monitor (U1-01)		
2005	41	Output Frequency Monitor (U1-02)		
2006	26	Output Current (0.01 A units for drives set to 11 kW in Heavy or Normal Duty and 0.1 A units for drives set to 15 kW and above.)		
2007	4F	Terminal A2 Input Level Monitor (U1-14)		
2008	46	DC Bus Voltage Monitor (U1-07)		
2009	C0	Error Signal 1	0	Reserved
			1	Undervoltage (Uv1)
			2	Control Power Supply Undervoltage (Uv2)
			3	Soft Charge Circuit Fault (Uv3)
			4	Reserved
			5	Ground Fault (GF)
			6	Overcurrent (oC)
			7	Overvoltage (ov)
			8	Heatsink Overheat (oH)
			9	Heatsink Overheat (oH1)
			A	Motor Overload (oL1)
			B	Drive Overload (oL2)
			C	Overtorque Detection 1 (oL3)
			D	Overtorque Detection 2 (oL4)
			E	Dynamic Braking Transistor Fault (rr)
F	Braking Resister Overheat (rH)			

## 7 Modbus TCP/IP Messaging

Address (hex)	Drive Register (hex)	Description	Bit	Description
200A	C1	Error Signal 2	0	External Fault at input terminal S3 (EF3)
			1	External Fault at input terminal S4 (EF4)
			2	External Fault at input terminal S5 (EF5)
			3	External Fault at input terminal S6 (EF6)
			4	External Fault at input terminal S7 (EF7)
			5	External Fault at input terminal S8 (EF8)
			6	Cooling fan Error (FAn)
			7	Overspeed (os)
			8	Excessive Speed Deviation (dEv)
			9	PG Disconnected (PGo)
			A	Input Phase Loss (PF)
			B	Output Phase Loss (LF)
			C	Motor Overheat (PTC input) (oH3)
			D	Digital Operator Connection Fault (oPr)
			E	EEPROM Write Error (Err)
			F	Motor Overheat Fault (PTC input) (oH4)
200B	C2	Error Signal 3	0	MEMOBUS/Modbus Communication Error (CE)
			1	Option Communication Error (bUS)
			2	Reserved
			3	Reserved
			4	Control Fault (CF)
			5	Zero Servo Fault (SvE)
			6	Option External Fault (EF0)
			7	PID Feedback Loss (FbL)
			8	Undertorque Detection 1 (UL3)
			9	UL4 Undertorque Detection 2 (UL4)
			A	High Slip Braking Overload (oL7)
			B	Reserved
			C	Reserved
			D	Reserved
E	Reserved			
F	Hardware Fault (includes oFX)			
200C	4E	Terminal A1 Input Level Monitor (U1-13)		
200D	49	Digital Input Terminal Status (U1-10)		
200E	50	Terminal A3 Input Level Monitor (U1-15)		
200F	F1	PG Count Channel 2		
2010	4D	Drive Software Number (Flash) (U1-25)		

## ◆ Enter Command Types

The drive supports two types of Enter Commands as shown in the table below. An Enter Command is enabled by writing 0 to register number 0900H or 0910H.

### ■ Enter Commands

**Table 10 Enter Command Types**

Register Number	Description
0900H	Writes data into the EEPROM (non-volatile memory) of the drive and enables the data to RAM at the same time. Parameter changes remain even if the power supply is cycled.
0910H	Writes data in the RAM only. Parameter changes are lost when the drive is shut off.

**Note:** Because the EEPROM can be written to a maximum of 100,000 times, refrain from frequently writing to the EEPROM. An Enter Command is not required if reference or broadcast data are sent to the drive.

## ◆ Enter Command Settings when Upgrading the Drive

When replacing earlier Yaskawa drive models with a 1000 Series drive and keeping the MEMOBUS/Modbus communications settings, parameter H5-11 needs to be set in accordance with how the Enter Command functions in the older drive. H5-11 determines if an Enter Command is needed or not in order to activate parameter changes in the drive.

- If upgrading from a G7 or F7 series drive to 1000 Series, set parameter H5-11 to 0.
- If upgrading from a V7 series drive to 1000 Series, set parameter H5-11 to 1.

### ■ Enter Commands

**Table 11 Enter Command Types**

H5-11 Settings	H5-11 = 0	H5-11 = 1
Drive being replaced.	G7, F7	V7
How parameter settings are enabled.	When the Enter Command is received from the master.	As soon as the value is changed.
Upper/lower limit check.	Upper/lower limit check is performed taking the settings of related parameters into account.	The upper/lower limit of the changed parameter is checked only.
Default value of related parameters.	Not affected. The settings of related parameters remain unchanged. Parameters must be changed manually if needed.	The default settings of related parameters are changed automatically.
Error handling when setting multiple parameters.	Data is accepted even if one setting is invalid. The invalid setting will be discarded. No error message occurs.	Error occurs if only one setting is invalid. All data sent is discarded.

## ◆ Message Format

The data section of the Modbus packet contains the Modbus message. In this data section, the master sends commands to the slave and the slave responds. The message format is configured for both sending and receiving as shown below, and the length of the packets depends on the command function content.

- UNIT IDENTIFIER
- FUNCTION CODE
- DATA

## 7 Modbus TCP/IP Messaging

### ■ Unit Identifier

This field is used for intra-system routing purposes. It is typically used to communicate to a Modbus+ or a Modbus serial line slave through a gateway between an Modbus TCP/IP network and a Modbus serial line. This field is set by the Modbus master in the command and must be returned with the same value in the response by the slave. This is sometimes referred to as the Unit ID. A drive using the SI-EM3 option has no gateway functionality.

### ■ Function Code

When sent by the master, this field identifies the command to be undertaken by the slave. It also identifies the format for the DATA section of the message. The slave normally echoes this command back to the master in its response message. When the most significant bit of this field is set in the response message, it signals an error condition has occurred.

### ■ Data

This field contains multiple bytes of varying length based upon the Function Code for commands and based upon the results of the command in the response. When sent by the master, this field contains details of the command that the slave will require to carry out the function. When sent by the slave, this field contains details of the response and sometimes error information.

## ◆ Modbus TCP/IP Option Function Details

### ■ 03 (03 Hex) Read Multiple Registers

This function code is used to read the contents of a contiguous block of registers. The command specifies the starting register and the number of registers. The normal response packs two bytes per register. For each register in the response, the first byte contains the most significant bits and the second byte contains the least significant bits.

**Table 12 Read Multiple Registers (Command)**

Description	Byte(s)	Data (Hex)
Slave Address	1	00 to FF
Function Code	1	03
Starting Register	2	0000 to FFFF
Quantity of Registers	2	*N
*N = Quantity of Registers (range is 1 - 16).		

**Table 13 Read Multiple Registers (Response)**

Description	Byte(s)	Data (Hex)
Slave Address	1	00 to FF
Function Code	1	03
Number of Data Bytes	1	2 x *N
Register Values	*N x 2	Values contained in slave registers.
*N = Quantity of Registers.		

**Table 14 Read Multiple Registers (Error Response)**

Description	Byte(s)	Data (Hex)
Slave Address	1	00 to FF
Error Code	1	83
Exception Code	1	See Modbus TCP/IP Exception Codes section.



Table 15 Example Read Multiple Registers Command

Description		Data (Hex)
Slave Address		02
Function Code		03
Starting Register	Upper	00
	Lower	20
Quantity of Registers	Upper	00
	Lower	04

Table 16 Example Read Multiple Registers Response

Description		Data (Hex)
Slave Address		02
Function Code		03
Number of Data Bytes		08
Starting Register	Upper	17
	Lower	70
Next Register	Upper	17
	Lower	70
Next Register	Upper	01
	Lower	09
Last Register	Upper	00
	Lower	00

Table 17 Example Read Multiple Registers Error Response

Description	Data
Slave Address	02
Error Code	83
Exception Code	02

## ■ 06 (06 Hex) Write Single Register

This function code is used to write to a single register in the drive. The command specifies the address of the register to be written and the value to write. The normal response is an echo of the request, returned after the register contents have been written.

Table 18 Write Single Register Command

Description	Byte(s)	Data (Hex)
Slave Address	1	00 to FF
Function Code	1	06
Register Address	2	0000 to FFFF
Register Value	2	0000 to FFFF

Table 19 Write Single Register Response

Description	Byte(s)	Data (Hex)
Slave Address	1	00 to FF
Function Code	1	06
Register Address	2	0000 to FFFF
Register Value	2	0000 to FFFF

## 7 Modbus TCP/IP Messaging

**Table 20 Write Single Register Error Response**

Description	Byte(s)	Data (Hex)
Slave Address	1	00 to FF
Error Code	1	86
Exception Code	1	See Modbus TCP/IP Exception Codes section.

**Table 21 Example Write Single Register Command**

Description		Data (Hex)
Slave Address		01
Function Code		06
Register Address	Upper	00
	Lower	01
Register Value	Upper	00
	Lower	03

**Table 22 Example Write Single Register Response**

Description		Data (Hex)
Slave Address		01
Function Code		06
Register Address	Upper	00
	Lower	01
Register Value	Upper	00
	Lower	03

**Table 23 Example Write Single Register Error Response**

Description	Data (Hex)
Slave Address	01
Error Code	86
Exception Code	21

### ■ 16 (10 Hex) Write Multiple Registers

This function code is used to write to a contiguous block of registers in the drive. The command specifies the starting register address, the number of registers and the values to be written. The command packs two bytes per register. For each register in the command the first byte contains the most significant bits and the second byte contains the least significant bits. The normal response returns the function code, starting address and quantity of registers written.

**Table 24 Write Multiple Register Command**

Description	Byte(s)	Data (Hex)
Slave Address	1	00 to FF
Function Code	1	10
Starting Register	2	0000 to FFFF
Quantity of Registers	2	*N
Number of Data Bytes	1	*N x 2
Register Values	*N x 2	0000 to FFFF

\*N = Quantity of Registers (range is 1 - 16).

Table 25 Write Multiple Register Response

Description	Byte(s)	Data (Hex)
Slave Address	1	00 to FF
Function Code	1	10
Starting Register	2	0000 to FFFF
Quantity of Registers	2	*N

\*N = Quantity of Registers

Table 26 Write Multiple Register Error Response

Description	Byte(s)	Data (Hex)
Slave Address	1	01
Error Code	1	90
Exception Code	1	See Modbus TCP/IP Exception Codes section.

Table 27 Example Write Multiple Registers Command

Description	Data (Hex)	
Slave Address	01	
Function Code	10	
Starting Register	Upper	00
	Lower	01
Quantity of Registers	Upper	00
	Lower	02
Number of Data Bytes	04	
First Register Data	Upper	00
	Lower	01
Next Register Data	Upper	02
	Lower	58

Table 28 Example Write Multiple Registers Response

Description	Data (Hex)	
Slave Address	01	
Function Code	10	
Starting Register	Upper	00
	Lower	01
Quantity of Registers	Upper	00
	Lower	02

Table 29 Example Write Multiple Registers Error Response

Description	Data (Hex)
Slave Address	01
Error Code	90
Exception Code	02

### ■ 23 (17 Hex) Read/Write Multiple Registers

This function code performs a combination of one read operation and one write operation in a single Modbus TCP/IP transaction. The write operation is performed before the read. The command specifies the starting read address, quantity of contiguous registers to read, starting write address, quantity of contiguous registers to write and the values to be written. The normal response contains the values of the registers that were read.

For both the address and the values, the first byte contains the most significant bits and the second byte contains the least significant bits.

**Table 30 Read/Write Multiple Registers Command**

Description	Byte(s)	Data (Hex)
Slave Address	1	00 to FF
Function Code	1	17
Read Starting Register	2	0000 to FFFF
Quantity of Registers to Read	2	*M
Write Starting Register	2	0000 to FFFF
Quantity of Registers to Write	2	*N
Write Byte Count	1	*N x 2
Write Register Values	*N x 2	0000 to FFFF
*M = Quantity of Registers to Read (range is 1 - 16), *N = Quantity of Registers to Write (range is 1 - 16).		

**Table 31 Read/Write Multiple Registers Response**

Description	Byte(s)	Data (Hex)
Slave Address	1	00 to FF
Function Code		17
Number of Data Bytes	1	*M x 2
Read Register Values	*M x 2	Values contained in slave registers.
*M = Quantity of Registers to Read.		

**Table 32 Read/Write Multiple Registers Error Response**

Description	Byte(s)	Data (Hex)
Slave Address	1	00 to FF
Error Code	1	97
Exception Code	1	See Modbus TCP/IP Exception Codes section.

**Table 33 Example Read/Write Multiple Registers Command**

Description		Data (Hex)
Slave Address		01
Function Code		17
Read Starting Register	Upper	00
	Lower	01
Quantity of Registers to Read	Upper	00
	Lower	02
Write Starting Register	Upper	01
	Lower	02
Quantity of Registers to Write	Upper	00
	Lower	02
Write Byte Count		04
First Write Register Data	Upper	01
	Lower	03
Next Write Register Data	Upper	02
	Lower	58

**Table 34 Example Read/Write Multiple Registers Response**

Description		Data (Hex)
Slave Address		01
Function Code		17
Number of data bytes		04
Read Data 1	Upper	00
	Lower	01
Read Data 2	Upper	00
	Lower	02

**Table 35 Example Read/Write Multiple Registers Error Response**

Description	Data (Hex)
Slave Address	01
Error Code	97
Exception Code	02

### ◆ Modbus TCP/IP Exception Codes

Sometimes an error may occur when the SI-EM3 option responds to a command. The response message will contain one of the Error Codes defined in [Table 36](#).

**Table 36 Modbus TCP/IP Exception Codes**

Error Code (Hex)	Error Name and Cause
01	Function Code Error. Attempted to set a function code from a PLC other than 03, 06, 10, or 17 (Hex).
02	Register Number Error. A register number specified in the command message does not exist.
03	Bit Count Error. <ul style="list-style-type: none"> <li>Invalid command message quantity</li> <li>In a write message, the value for write byte count does not match twice the value of the stated quantity of registers to write</li> </ul>
21	Data Setting Error. <ul style="list-style-type: none"> <li>Control data or parameter write data is outside the allowable setting range</li> <li>Attempted to write a contradictory parameter setting</li> </ul>
22	Write Mode Error. <ul style="list-style-type: none"> <li>Attempted to write while the drive was operating to a parameter that cannot be written during run</li> <li>During an EEPROM data error (CPF06), the master attempted to write to parameter other than A1-00 to -05, E1-03, or o2-04</li> <li>Attempted to write to a read-only register</li> </ul>
23	DC Bus Undervoltage Write Error. <ul style="list-style-type: none"> <li>Attempted to write from the master during an undervoltage fault (Uv1)</li> <li>Attempted to execute an Enter command during Uv1</li> </ul>
24	Write Error During Parameter Process. Master attempted writing to the drive while the drive was processing parameter data.

### ◆ Control Connection Timeout

The SI-EM3 option has a safety feature that declares a fault if communications between the master and drive is lost after the master commanded the drive to run.

A controlled connection is defined as one in which a master commands the drive by writing to register 01H. After this write, the SI-EM3 option will begin a timer. The timer will be reset upon subsequent writes to register 01H. If the timer exceeds the value programmed in drive parameter F7-16, then the SI-EM3 will declare a BUS ERROR to the drive. A value of 0 in F7-16 means that the timeout is disabled.

The drive reaction to a BUS ERROR is programmable through drive parameter F6-01.

## 8 Web Interface

The web server interface to the drive SI-EM3 option allows management of diagnostic information through a standard web browser. The embedded web pages include:

- Main page
- Drive Status page
- Network Monitor page
- Documentation page

### ◆ Main Page

The embedded main page shows basic SI-EM3 option information such as IP address, MAC address, and firmware version. This page also shows the status of the SI-EM3 option, and provides links to the other embedded web pages.

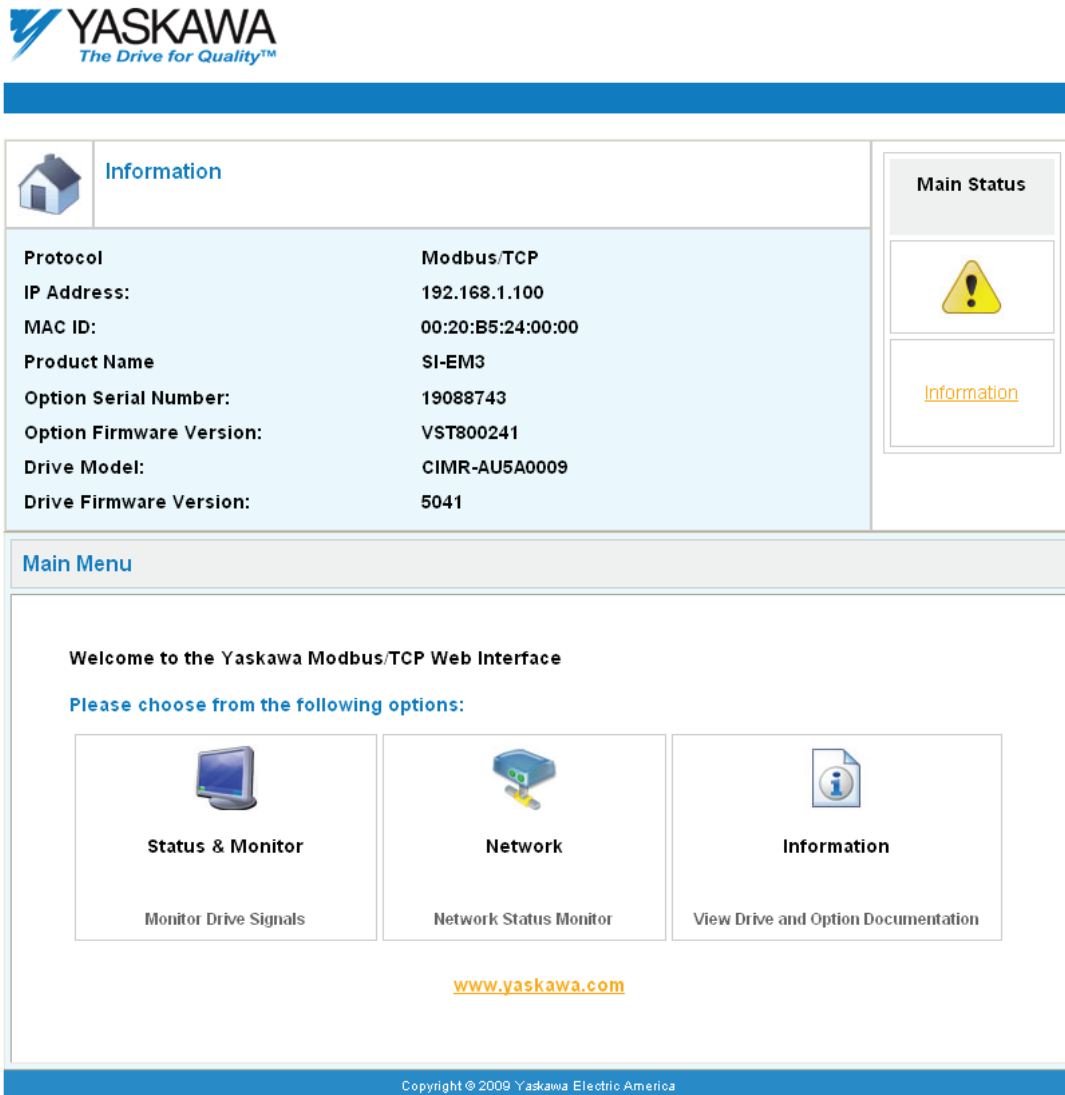



Figure 10 Main Page View

## ◆ Drive Status Page

The embedded drive status page shows basic I/O information and drive state information.





**Status, Monitor and Fault History**



### Drive Signals

Stopped	On	Forward	On	Alarm	Off
Running	Off	Reverse	Off	Fault	Off

Drive Signals	Multi-function Inputs	Multi-function Outputs
Frequency Ref. <b>0.00 Hz</b>	Terminal S1 <b>Off</b>	Output MA/MB-MC <b>Off</b>
Output Frequency <b>0.00 Hz</b>	Terminal S2 <b>Off</b>	Output P1 - PC <b>On</b>
Output Current <b>0.0</b> A.	Terminal S3 <b>Off</b>	Output P2 - PC <b>Off</b>
DC Bus Voltage <b>679</b> VDC	Terminal S4 <b>Off</b>	
Torque Ref <b>0.0</b> %	Terminal S5 <b>Off</b>	
	Terminal S6 <b>Off</b>	
	Terminal S7 <b>Off</b>	
	Terminal S8 <b>Off</b>	
	Terminal S9 <b>NA</b>	
	Terminal S10 <b>NA</b>	
	Terminal S11 <b>NA</b>	
	Terminal S12 <b>NA</b>	

### Analog Input Signals

Input Terminal A1	0.0	%
-------------------	-----	---

### Fault Information

Active:    None



Copyright © 2009 Yaskawa Electric America

**Figure 11 Drive Status Page View**

◆ Network Monitor Page

The embedded network monitor page shows the status of the option network traffic and open I/O connections.



	<b>Network Monitor</b>				
<b>Diagnostics</b>					
Msg. TX OK	1528	Msg. TX Dropped	0	Msg. TX Errors	0
Msg. Rx OK	1968	Msg. Rx Dropped	0	Msg. RX Errors	0
Current Connections	0	Collisions	0	TX Retry	0
Control Connection Delta Time	N/A				
Copyright © 2009 Yaskawa Electric America					

**Figure 12 Network Monitor Page View**  
**Table 37 Network Monitor Explanations**

Network Monitor	Explanation
Msg Tx OK	Cumulative number of messages transmit successfully from SI-EM3.
Msg Rx OK	Cumulative number of messages received successfully to SI-EM3.
Current Connections	Current number of open connections.
Control Connection Delta Time	The time between the last two writes to the Control register, MEMOBUS/Modbus address 0001H.
Msg Tx Dropped	Cumulative number of messages dropped due to output network buffer being full and unable to hold the new message.
Msg Rx Dropped	Cumulative number of messages dropped due to input network buffer being full and unable to hold the new message.
Collisions	Cumulative number of collisions (half duplex only) reported by the MAC/PHY (Media Access Control/Physical Connection).
Msg Tx Errors	Cumulative number of transmit underruns and transmit stops reported by the MAC/PHY.
Msg Rx Errors	Cumulative number of receive overruns, receive stops, and receive error frames reported by the MAC/PHY.
Tx Retry	Cumulative number of transmits in which the 1st attempt was delayed due to busy medium reported by the MAC/PHY.
<b>Note:</b> Cumulative counters are reset when the power supply is cycled.	









## ◆ Documentation Page

The embedded documentation page contains links to SI-EM3 option documentation on the Yaskawa website.



Documentation

 Documentation

Document	Description	
<b>Installation Manual</b>	SI-EM3/V EtherNet Modbus TCP/IP for V1000	
<b>Technical Manual</b>	SI-EM3/V EtherNet Modbus TCP/IP for V1000	
<b>Installation Manual</b>	SI-EM3 EtherNet Modbus TCP/IP for A1000/E1000/T1000	
<b>Technical Manual</b>	SI-EM3 EtherNet Modbus TCP/IP for A1000/E1000/T1000	

NOTE: INTERNET CONNECTION IS REQUIRED TO VIEW/OPEN DOCUMENTS.

Copyright © 2008 Yaskawa Electric America

**Figure 13 Documentation Page View**

## 9 Troubleshooting

### ◆ Drive-Side Error Codes

Drive-side error codes appear on the drive digital operator. Causes of the errors and corrective actions are listed in [Table 38](#). For additional error codes that may appear on the drive digital operator, refer to the drive Technical Manual.

#### ■ Faults

Both bUS (SI-EM3 option communication error) and EF0 (External fault input from the SI-EM3 option) can appear as an alarm or as a fault. When a fault occurs, the digital operator ALM LED remains lit. When an alarm occurs, the ALM LED flashes.

If communication stops while the drive is running, use the following questions as a guide to help remedy the fault:

- Is the option properly installed?
- Is the communication line properly connected to the option? Is it loose?
- Is the controller program working? Has the controller/PLC CPU stopped?
- Did a momentary power loss interrupt communications?

**Table 38 Fault Display and Possible Solutions**

LED Operator Display		Fault Name
<i>bUS</i>	bUS	SI-EM3 option communication error.
		<ul style="list-style-type: none"> <li>• After establishing initial communication, the connection was lost</li> <li>• Only detected when the run command or frequency reference is assigned to the option (b1-01 = 3 or b1-02 = 3).</li> </ul>
Cause		Possible Solution
Master controller (PLC) has stopped communicating		<ul style="list-style-type: none"> <li>• Check that power is supplied to the PLC.</li> <li>• Check that PLC is not in program mode.</li> </ul>
Communication cable is not connected properly		<ul style="list-style-type: none"> <li>• Check for faulty wiring.</li> <li>• Correct any wiring problems.</li> </ul>
A data error occurred due to noise		<ul style="list-style-type: none"> <li>• Check the various options available to minimize the effects of noise.</li> <li>• Counteract noise in the control circuit, main circuit, and ground wiring.</li> <li>• If a magnetic contactor is identified as a source of noise, install a surge absorber to the contactor coil.</li> <li>• Make sure the cable used meets the Modbus TCP/IP requirements.</li> <li>• Make sure the option ground wire is connected between option FE terminal and the drive ground terminal connected to earth ground.</li> </ul>
SI-EM3 option is damaged		If there are no problems with the wiring and the error continues to occur, replace the SI-EM3 option.
Control Connection Timeout		The control connection timer value set in F7-16 has timed out.
Duplicate IP Address		The SI-EM3 option shares IP Address with at least one other node.

LED Operator Display		Fault Name
<i>EF0</i>	EF0	External fault input from SI-EM3 option.
		The alarm function for an external device has been triggered.
Cause		Corrective Action
An external fault is being sent from the upper controller (PLC)		<ul style="list-style-type: none"> <li>• Remove the cause of the external fault.</li> <li>• Reset the external fault input from the PLC device.</li> </ul>
Problem with the PLC program		Check the program used by the PLC and make the appropriate corrections.

LED Operator Display		Fault Name
oFA00	oFA00	SI-EM3 option fault.
		SI-EM3 option is not properly connected.
Cause		Possible Solution
Non-compatible option connected to the drive		Connect an option that is compatible with the drive.

LED Operator Display		Fault Name
oFA01	oFA01	SI-EM3 option fault.
		SI-EM3 option is not properly connected.
Cause		Possible Solution
Problem with the connectors between the drive and SI-EM3 option		Turn the power off and check the connectors between the drive and SI-EM3 option.

LED Operator Display		Fault Name
oFA03	oFA03	SI-EM3 option fault.
		SI-EM3 option self-diagnostics error.
Cause		Possible Solution
SI-EM3 option hardware fault		Replace the SI-EM3 option.

LED Operator Display		Fault Name
oFA04	oFA04	SI-EM3 option fault.
		SI-EM3 option flash write mode.
Cause		Possible Solution
SI-EM3 option hardware fault		Replace the SI-EM3 option.

LED Operator Display		Fault Name
oFA30 to oFA43	oFA30 to oFA43	SI-EM3 option Fault (Port A).
		Communication ID error.
Cause		Possible Solution
SI-EM3 option hardware fault		Replace the SI-EM3 option.

LED Operator Display		Fault Name
oFb00	oFb00	SI-EM3 option fault (CN5-B).
		Non-compatible option is connected.
Cause		Possible Solution
Non-compatible option connected to the drive.		Connect the correct option to CN5-A.

LED Operator Display		Fault Name
oFb02	oFb02	SI-EM3 option fault (CN5-B).
		Two of the same options are connected at the same time.
Cause		Possible Solution
Options AI-A3 or DI-A3 were connected to the CN5-B port while an option was already connected to CN5-A.		Only one type of option input AI-A3 or DI-A3 can be connected to the drive. Only the SI-EM3 option can be connected to CN5-A.

## 9 Troubleshooting

LED Operator Display		Fault Name
oFc00	oFc00	SI-EM3 option fault (CN5-C). Non-compatible option is connected.
Cause		Possible Solution
Non-compatible option connected to the drive.		Connect the correct option to CN5-A.

LED Operator Display		Fault Name
oFc02	oFc02	SI-EM3 option fault. SI-EM3 option flash write mode.
Cause		Possible Solution
Options AI-A3 or DI-A3 were connected to the CN5-B port while an option was already connected to CN5-A.		Only one type of option AI-A3 or DI-A3 can be connected to the drive. Only this option for SI-EM3 can be connected to CN5-A.

### ■ Minor Faults and Alarms

LED Operator Display		Minor Fault Name	
CALL	CALL	Serial communication transmission error. Communication is not established.	
Cause		Possible Solution	Minor Fault (H2-□□ = 10)
Communication wiring is faulty, there is a short circuit, or improper connection		Check for wiring errors: <ul style="list-style-type: none"> <li>• Correct the wiring.</li> <li>• Remove ground shorts and reconnect loose wires.</li> </ul>	YES
Programming error on the master side		Check communications at start-up and correct programming errors	
Communication circuitry is damaged.		<ul style="list-style-type: none"> <li>• Perform a self-diagnostics check.</li> <li>• Replace the drive if the fault continues to occur.</li> </ul>	

### ◆ SI-EM3 Option Error Codes

#### ■ SI-EM3 Option Fault Monitors U6-98 and U6-99

The SI-EM3 option can declare error/warning conditions via drive monitor parameters on the drive digital operator as shown in [Table 39](#).

**Table 39 SI-EM3 Option Fault Monitor Descriptions**

Fault Condition	Fault Declared	Status Value (U6-98/U6-99)	Description
No Fault	n/a	0	No faults.
Force Fault	EF0	3	Network sent a message to force this node to the fault state.
Network Link Down	BUS ERROR	1200	No network link to the option.
Connection Time-out	BUS ERROR	1201	The control connection timer (F7-16) timed out.
Duplicate IP Address	BUS ERROR	1202	This node and at least one other node have the same IP Address.
Default MAC Address	None	1203	Factory default MAC Address programmed into the SI-EM3 option. Return for reprogramming.

Two drive monitor parameters, U6-98 and U6-99 assist the user in network troubleshooting.

- U6-98 displays the first declared fault since the last power cycle. U6-98 is only cleared upon drive power-up.
- U6-99 displays the present SI-EM3 option status. U6-99 is cleared upon a network-issued fault reset and upon power-up.

If another fault occurs while the original fault is still active, parameter U6-98 retains the original fault value and U6-99 stores the new fault status value.

## ◆ Option Compatibility

A limited number of options may be simultaneously connected to the drive depending on the type of option. Refer to [Table 40](#) for more information. More details can be found in the Options and Peripheral Devices chapter of the drive Technical Manual.

**Table 40 Option Installation Compatibility**

Option	Connector	Number of Possible Options
SI-C3, SI-N3, SI-P3, SI-S3, SI-EM3 <1>	CN5-A	1
PG-B3, PG-X3	CN5-B, C	2 <2>
DO-A3, AO-A3, AI-A3, DI-A3	CN5-A, B, C	1

<1> When installed in CN5-A, the AI-A3 and DI-A3 options can be used to set the frequency reference or replace the drive analog inputs with higher resolution. When installed in CN5-B or CN5-C, these options can only be used for monitoring; their input levels will be displayed in U1-17 and U1-21 to U1-23.

<2> Use the CN5-C connector when connecting only one option to the drive; use both CN5-B and CN5-C when connecting two options.

# 10 Specifications

## ◆ Specifications

**Table 41 Option Specifications**

Item	Specification
Model	SI-EM3 (PCB model: UTC000310)
SI-EM3 Supported Messages	<ul style="list-style-type: none"> <li>• Read Multiple Registers (03H)</li> <li>• Write Single Register (06H)</li> <li>• Write Multiple Registers (10H)</li> <li>• Read and Write Registers (17H)</li> </ul> Commands that support multiple registers have a maximum Read and Write size of 16 registers.
Option Conformance	Passed
Connector Type	RJ45 8-pin Shielded Twisted Pair Cat 5e cable
Physical Layer Type	<ul style="list-style-type: none"> <li>• Isolated Physical Layer</li> <li>• TCP Protocol Transformer Isolated</li> </ul>
IP Address Setting	Programmable from drive keypad or network
Communication Speed	Programmable from drive keypad or network: 10/100 Mbps, auto-negotiate.
Number of Connections	Modbus TCP/IP: 10 Web Page Access: 2
Duplex Mode	Half-forced, Auto-negotiate, Full-forced
Address Startup Mode	Static, BOOTP, DHCP
Ambient Temperature	-10 °C to +50 °C
Humidity	Up to 95% RH (no condensation)
Storage Temperature	-20 °C to +60 °C (allowed for short-term transport of the product)
Area of Use	Indoor (free of corrosive gas, airborne particles, etc.)
Altitude	1000 m or lower







## YASKAWA AC Drive -1000 Series Option

# Modbus TCP/IP Technical Manual

---

### **YASKAWA ELECTRIC AMERICA, INC.**

2121 Norman Drive South, Waukegan, IL 60085, U.S.A.

Phone: 1-847-887-7000 or (800)YASKAWA (800-927-5292) Fax: 1-847-887-7310

Internet: <http://www.yaskawa.com>

### **YASKAWA ELÉTRICO DO BRASIL LTDA.**

Avenida Fagundes Filho, 620 São Paulo-SP CEP 04304-000, Brazil

Phone 55-11-3585-1100 Fax 55-11-5581-8795



YASKAWA ELECTRIC AMERICA, INC.

YASKAWA

In the event that the end user of this product is to be the military and said product is to be employed in any weapons systems or the manufacture thereof, the export will fall under the relevant regulations as stipulated in the Foreign Exchange and Foreign Trade Regulations. Therefore, be sure to follow all procedures and submit all relevant documentation according to any and all rules, regulations and laws that may apply.

Specifications are subject to change without notice for ongoing product modifications and improvements.

© 2009 YASKAWA ELECTRIC AMERICA INC. All rights reserved.



SIEPYEACOM05

MANUAL NO. SIEP YEACOM 05A

Published in U.S.A. August 2009 09-8  
09-08-1