

# A1000

240V Class:  $\frac{3}{4}$  to 175 HP  
480V Class:  $\frac{3}{4}$  to 1000 HP  
600V Class: 1 to 250 HP



# YASKAWA

## **A Single Drive for all Your Needs, with Outstanding Performance and Flexibility!**

The A1000 is a full-featured drive, providing outstanding quality, performance, flexibility, and environmental friendliness through 1000HP. From simple fans and pumps to complex machine control, A1000 can be the single drive platform for an entire facility. Network communications, expandable I/O, and feedback are among the many choices. For new installations or retrofits, the A1000 provides a single robust solution, regardless of your application.

# **Yaskawa A1000 Family of AC Drives**



Configured A1000  
Drive Package

Standard A1000 Drives

# Contents

Features, Benefits and Specifications	4	
Drive and Accessories Selection	16	
Mechanical Installation Planning	41	
Electrical Installation Planning	46	
A1000 Configured Package	50	
Yaskawa Industrial Drives Family	52	
Global Service Network	54	



# Features and Benefits

## Exceptional Quality

Enjoy peace of mind by knowing that you are considering a product from Yaskawa, the factory automation controls company with the highest reputation for quality and reliability. Historically, Yaskawa drives have demonstrated extremely high reliability with an average MTBF (mean time between failure) of 28 years or more. The new 1000 series products take reliability to the next level with a calculated design life that is twice as long as previous generations.



**Highly Integrated Design** results in fewer parts and interconnections, reducing the number of failure points.

**Component Derating** extends the life of any single part by selecting higher specifications (e.g. voltage, current) than what a circuit requires for normal operation.

**Latest Generation IGBT Power Modules**, capable of four times more thermal cycles than previous designs.

**Enhanced Short Circuit Detection and Self Diagnostics** provide additional protection against severe catastrophic conditions.

In addition, the A1000 is designed for use around the world, and carries agency certifications for all major geographical regions

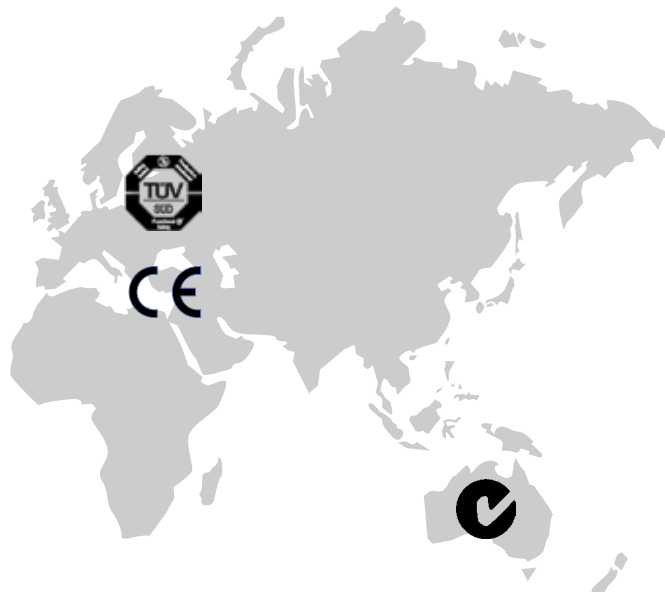

## Easy to Apply and Maintain

Whether your applications are simple or complex, the A1000 is supported by user-friendly configuration tools. For local field access, the keypad interface features a multi-language LCD display, parameter storage, and application presets to make programming a simple task. It also has built-in memory for backup purposes. In addition, a USB Copy Unit can be loaded with a drive's program for convenient portable transfer of configuration between an office environment and the factory floor.

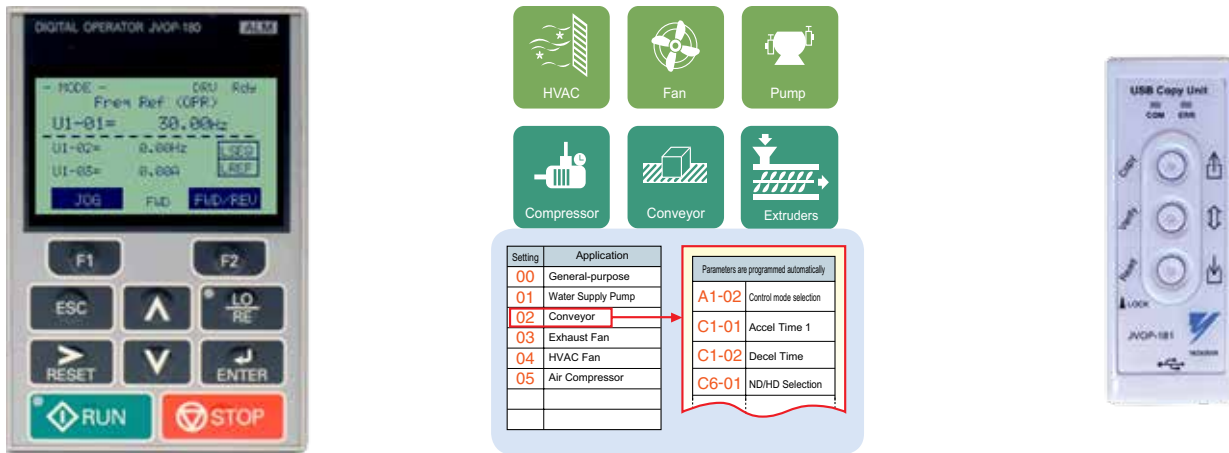

DriveWizard® computer software delivers configuration, monitoring, and trending functions enhanced by direct connectivity through the A1000's standard USB port.

- Online and Offline Editing
- Application Wizard
- Monitoring and Diagnostic Panels
- Trend Recorder and Playback
- Network Configurator
- Multidrive Support
- Drive Flash Support
- Project Converter
- Report and Export Generation
- Search Engine



# Features and Benefits

## Easy to Apply and Maintain

### Preventative Maintenance Monitors

Maximize production and intelligently schedule your maintenance by making use of the A1000's special monitors that provide alarm information when a drive requires attention. Use this information to trigger discrete outputs or send the status across a network for upper level decision making.

- Cooling Fan Remaining Life
- IGBT (Power Module) Remaining Life
- Bus Capacitor Remaining Life
- Precharge Relay
- Drive (Heatsink) Temperature



### Highly Reliable and Easily Replaceable Cooling Fans

- Improved location for convenient access
- No tools required
- 24Vdc powered (including large ratings) eliminates need to make proper connection at time of installation



### Removeable I/O Terminal Board with Drive Backup Memory

- All parameter changes automatically saved to both main control board and I/O board
- Leave I/O connected when replacing a drive
- Configuration is downloaded to replacement drive
- Reduces MTTR (Mean Time To Repair)



## Maximum Flexibility

Have it your way with the A1000's impressive flexibility. Take advantage of a significant quantity of control points as standard. For applications requiring more I/O, feedback, or network choices, the A1000 offers three expansion ports that support a wide variety of interface modules.



### Standard I/O and Communications

- Digital Inputs (8)
- Analog Inputs (3)
- Pulse Inputs (1)
- Digital Outputs (4)
- Analog Outputs (2)
- Pulse Outputs (1)
- RS485 Modbus RTU Communication

### Expansion Capability

#### I/O Modules

- Digital Inputs (16)
- Analog Inputs (3)
- Digital Outputs (8)
- Analog Outputs (2)

#### Feedback Modules

- Incremental Encoder
- Resolver
- Absolute Encoder (Stegmann, Heidenhain)

#### Communication Modules

- DeviceNet
- EtherNet/IP
- Modbus TCP/IP
- PROFIBUS-DP
- PROFINET
- MECHATROLINK-II
- EtherCAT
- Metasys N2/Apogee FLN (P1)
- BACnet
- LonWorks



# Features and Benefits

## Maximum Flexibility

### Auxiliary Control Power Input

Keep your drives communicating over the network, even while main power is removed. The Auxiliary Control Power Input uses facility supplied 24Vdc to keep the drive's control and communication intact. Service your drive cabinets with the benefit of live control and communications without the need for main power and associated Arc Flash protection.



### Embedded Functional Safety

Minimize downtime for applications requiring occasional or frequent mechanical intervention. Safe Torque Off provides safe removal of torque without removal of power to the drive. The A1000 provides this functionality as standard in a safety category 3 architecture, and is certified by TUV to PLd and SIL CL2 according to ISO/EN 13849-1 and IEC/EN 62061 respectively, meeting the requirements of IEC/EN 61508.

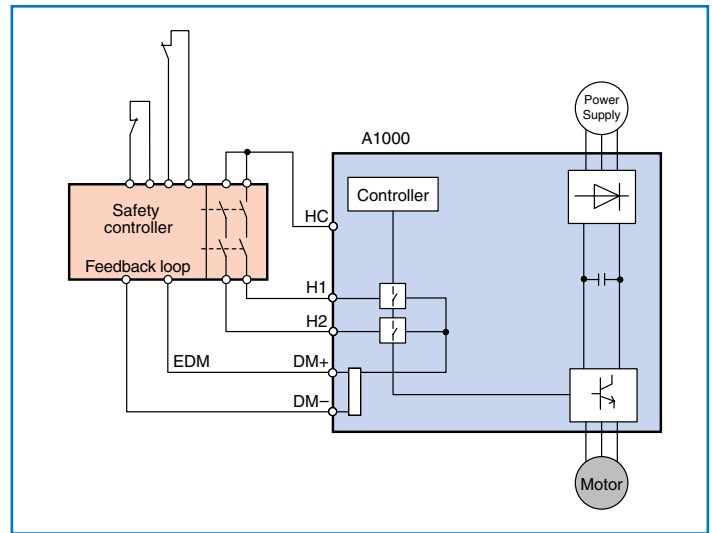

## Space Saving Features

The A1000 offers world class power density resulting in an average size reduction of 30% as compared to previous generations (see individual rating dimensions). In addition, even more cabinet space can be saved by taking advantage of External Heatsink Mounting or its Zero Side Clearance capability.

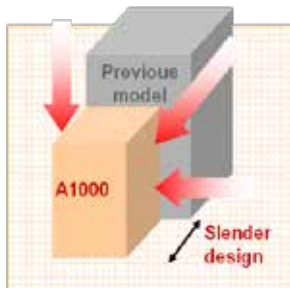

Physical Size Reduction

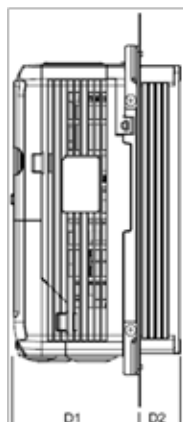

External Heatsink Solution  
(Side View)



Zero Side Clearance  
(40°C max ambient)



## Maximum Flexibility

A variety of braking solutions optimized for your application.

- For high demand braking conditions, the A1000 provides powerful Dynamic Braking with integrated brake transistors through 50HP normal duty (40HP heavy duty). For drives rated through 7.5HP normal duty (5HP heavy duty), drive mounted low duty cycle resistors are available
- For applications that can dissipate losses in the motor, Over-Excitation Braking and High Slip Braking are good performing, money saving alternatives to dynamic braking

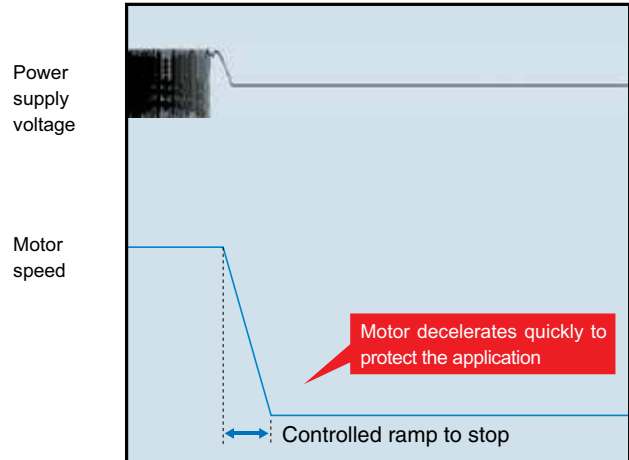

- In the event of a power loss, Kinetic Energy Braking uses energy stored in the rotating load to keep the drive powered and bring the process to a controlled stop

Keep your applications running with features designed to avoid interruptions that are typical with demanding load conditions.

- Optimal Decel automatically extends the programmed deceleration time based on the load condition and drive capability
- Overvoltage Suppression limits the DC bus voltage by modulating output frequency to keep the drive out of the regenerative region
- Overload Fault Prevention responds to heavy load conditions by adjusting output frequency and voltage to keep the drive's current within operating limits
- Momentary Power Loss Ride-Thru puts the drive in standby mode during transient power losses and then automatically restarts, avoiding potentially costly power related shut down conditions

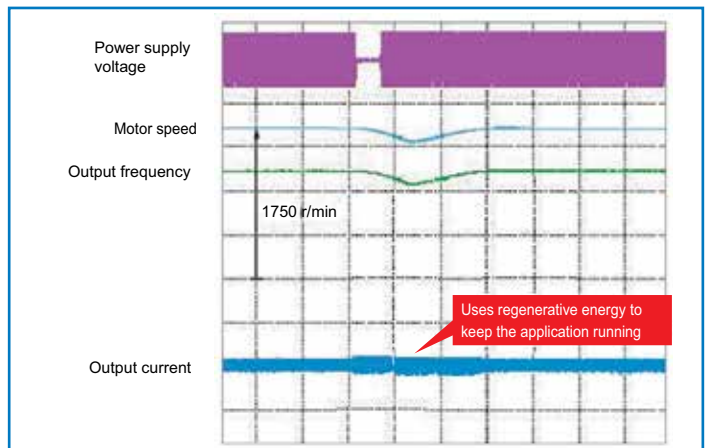

- Speed Search allows the drive to start into a rotating load by quickly matching its speed before delivering full power

# Features and Benefits

## Maximum Flexibility

- Embedded Application Functions provide system level control without the use of a stand-alone controller.
- PID (Proportional Integral Derivative) Control regulates your process variable (flow, pressure, etc.).
- Droop Control automatically adjusts motor slip to perform load sharing in a multi-drive system.
- Function Block Programming supported by DriveWorksEZ® offers internal logic functions to build the application of your choice.
  - Drag and Drop Graphical Environment
  - Interface with I/O, Drive Data, Network Data
  - Logic Functions
  - Math Functions
  - Timers
  - Counters
  - Subroutine Creation
  - Up to 289 Function Blocks
  - Up to 100 Connections
  - 1 millisecond execution

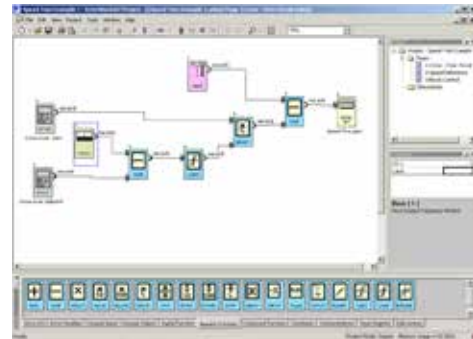

A single drive to control traditional and emerging motor technologies:

- **Induction Motors**
  - Low cost
  - Widely available
  - Efficient
- **Interior Permanent Magnet (IPM) Motors**
  - Very Compact
  - Highly Efficient
  - Sensorless High Precision Control
- **Surface Permanent Magnet (SPM) Motors**
  - Ultra Compact
  - Highly Efficient

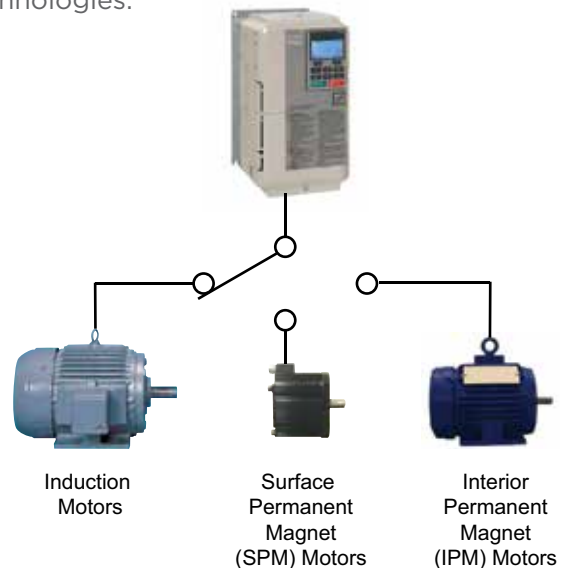

## Type 12 Flange Configuration

A1000 is available in all ratings as a Type 12 Flange configuration that allows for mounting the drive with its heatsink out the back of any Type 12 enclosure. This allows for the majority of the drive's heat to dissipate on the external side, while keeping the enclosure small and sealed with Type 12 integrity.



## Outstanding Performance

The A1000 delivers incredible performance, producing up to 200% torque with or without feedback.

- Continuous Autotuning automatically compensates for changes in motor temperature
- Inertia Autotuning automatically sets gains for speed and torque loops
- Dead-Time Compensation drastically reduces torque ripple at low speeds
- High Frequency Injection (for IPM motors) enables high precision control without feedback, including positioning to within  $\pm 5$  degrees !

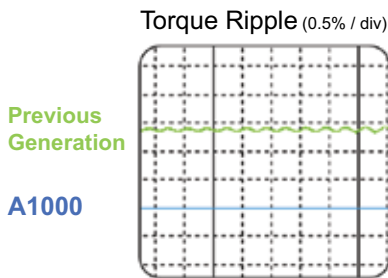
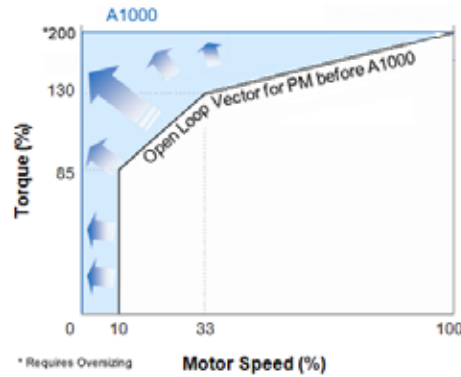

Speed Control Range	1500:1 Closed Loop Vector (Induction and PM Motors) 200:1 Open Loop Vector (Induction Motors) 100:1 Open Loop Vector (IPM Motors)
Speed Accuracy	0.02% - Closed Loop Vector (Induction Motors) 0.2% - Open Loop Vector (Induction Motors) 0.00% - Closed Loop Vector (IPM & SPM Motors) 0.00% - Open Loop Vector (IPM Motors)
Speed Response	60 Hz - Closed Loop Vector 10 Hz - Open Loop Vector
Torque Response	300 Hz - Closed Loop Vector

## Environmentally Friendly

Reduce your energy bill and contribute towards a cleaner environment with sustainable features designed into the A1000.

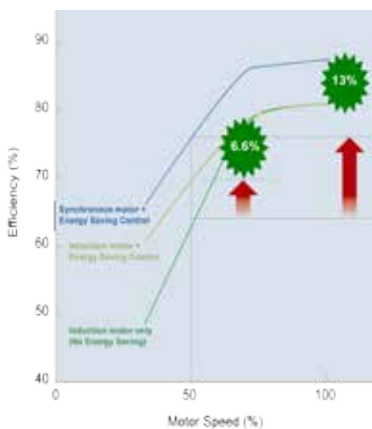

Applying variable speed often results in large energy savings. Combining this with more efficient motors magnifies the result.

Built-in DC Reactors (30 HP and larger) provide input harmonics benefit, and protection from input disturbances.

To further reduce harmonics reflected back to the utility power line, the A1000 is available with an integrated 12-pulse diode bridge from 40 to 1000 HP @ 480 VAC (also requires the use of an external phase shifting transformer)

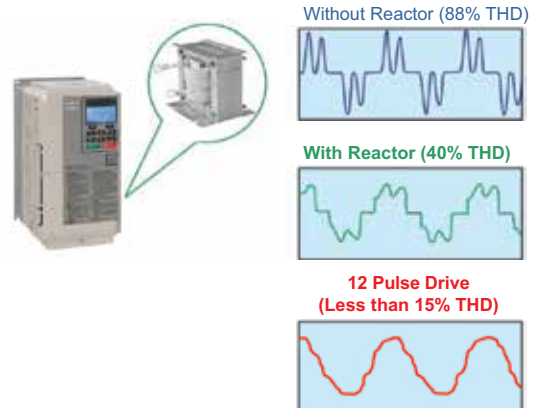

All materials used in the A1000 comply with the directive for Restriction of Hazardous Substances (RoHS)

# Specifications

## 240V Class

Model	CIMR-AU2A		0004	0006	0008	0010	0012	0018	0021	0030	0040	0056
Max. Applicable Motor Capacity <sup>1</sup>	HP	Normal Duty	0.75	1.5	2	3	3	5	7.5	10	15	20
		Heavy Duty	0.75	1	2	2	3	3	5	7.5	10	15
Input	Rated Input Current <sup>2</sup>	A	3.9	7.3	8.8	10.8	13.9	18.5	24	37	52	68
		Heavy Duty	2.9	5.8	7	7.5	11	15.6	18.9	28	37	52
Output	Rated Output Capacity <sup>4</sup>	kVA	1.3	2.3	3	3.7	4.6	6.7	8	11.4	15.2	21
		Normal Duty <sup>5</sup>	1.3	2.3	3	3.7	4.6	6.7	8	11.4	15.2	21
	Heavy Duty	1.2 <sup>6</sup>	1.9 <sup>6</sup>	2.6 <sup>6</sup>	3 <sup>6</sup>	4.2 <sup>6</sup>	5.3 <sup>6</sup>	6.7 <sup>6</sup>	9.5 <sup>5</sup>	12.6 <sup>5</sup>	17.9 <sup>5</sup>	
	Rated Output Current	A	3.5	6	8	9.6	12	17.5	21	30	40	56
		Normal Duty <sup>5</sup>	3.5	6	8	9.6	12	17.5	21	30	40	56
	Heavy Duty	3.2 <sup>6</sup>	5 <sup>6</sup>	6.9 <sup>6</sup>	8 <sup>6</sup>	11 <sup>6</sup>	14 <sup>6</sup>	17.5 <sup>6</sup>	25 <sup>5</sup>	33 <sup>5</sup>	47 <sup>5</sup>	
Overload Tolerance	Normal Duty Rating: 120% of rated output current for 60 sec. Heavy Duty Rating: 150% of rated output current for 60 sec. (Derating may be required for applications that start and stop frequently)											
Carrier Frequency (User Adjustable)	2 to 15 kHz											
Max. Output Voltage	Three-phase 200 to 240 V (relative to input voltage)											
Max. Output Frequency	400 Hz											
Rated Voltage/Rated Frequency	Three-phase 200 to 240 Vac 50/60 Hz 270 to 340 Vdc <sup>3</sup>											
Allowable Voltage Fluctuation	-15% to +10%											
Allowable Frequency Fluctuation	±5%											
Braking Transistor	Included											
Fan	No fan						With fan					
DC Link Choke	External Option											
Power Supply	kVA	Normal Duty	2.2	3.1	4.1	5.8	7.8	9.5	14	18	27	36
		Heavy Duty	1.3	2.2	3.1	4.1	5.8	7.8	9.5	14	18	27

Model	CIMR-AU2A		0069	0081	0110	0138	0169	0211	0250	0312	0360	0415
Max. Applicable Motor Capacity <sup>1</sup>	HP	Normal Duty	25	30	40	50	60	75	100	125	150	175
		Heavy Duty	20	25	30	40	50	60	75	100	125	150
Input	Rated Input Current <sup>2</sup>	A	80	96	111	136	164	200	271	324	394	471
		Heavy Duty	68	80	82	111	136	164	200	271	324	394
Output	Rated Output Capacity <sup>4</sup>	kVA	26	31	42	53	64	80	95	119	137	158
		Normal Duty <sup>5</sup>	26	31	42	53	64	80	95	119	137	158
	Heavy Duty	23 <sup>6</sup>	29 <sup>6</sup>	32 <sup>6</sup>	44 <sup>6</sup>	55 <sup>6</sup>	69 <sup>7</sup>	82 <sup>7</sup>	108 <sup>7</sup>	132 <sup>7</sup>	158 <sup>5</sup>	
	Rated Output Current	A	69	81	110	138	169	211	250	312	360	415
		Normal Duty <sup>5</sup>	69	81	110	138	169	211	250	312	360	415
	Heavy Duty	60 <sup>6</sup>	75 <sup>6</sup>	85 <sup>5</sup>	115 <sup>6</sup>	145 <sup>6</sup>	180 <sup>7</sup>	215 <sup>7</sup>	283 <sup>7</sup>	346 <sup>7</sup>	415 <sup>5</sup>	
Overload Tolerance	Normal Duty Rating: 120% of rated output current for 60 sec. Heavy Duty Rating: 150% of rated output current for 60 sec. (Derating may be required for applications that start and stop frequently)											
Carrier Frequency (User Adjustable)	2 to 15 kHz						2 to 10 kHz					
Max. Output Voltage	Three-phase 200 to 240 V (relative to input voltage)											
Max. Output Frequency	400 Hz (user-set)											
Rated Voltage/Rated Frequency	Three-phase 200 to 240 Vac 50/60 Hz 270 to 340 Vdc <sup>3</sup>											
Allowable Voltage Fluctuation	-15% to +10%											
Allowable Frequency Fluctuation	±5%											
Braking Transistor	Included						External Option					
Fan	With fan											
DC Link Choke	External Option						Included					
Power Supply	kVA	Normal Duty	44	52	51	62	75	91	124	148	180	215
		Heavy Duty	36	44	37	51	62	75	91	124	148	180

\*1. The motor capacity (HP) refers to a NEC rated 4-pole motor. The rated output current of the drive output amps should be equal to or greater than the motor current. Select the appropriate capacity drive if operating the motor continuously above motor nameplate current.

\*2. Assumes operation at the rated output current. Input current rating varies depending on the power supply transformer, input reactor, wiring connections, and power supply impedance.

\*3. DC is not available for UL/CE standards.

\*4. Rated motor capacity is calculated with a rated output voltage of 230V.

\*5. Carrier frequency is set to 2 kHz. Current derating is required in order to raise the carrier frequency.

\*6. Carrier frequency can be increased to 8 kHz while keeping this current derating. Higher carrier frequency settings require derating.

\*7. Carrier frequency can be increased to 5 kHz while keeping this current derating. Higher carrier frequency settings require derating.

## 480V Class

Model	CIMR-AU4A	0002	0004	0005	0007	0009	0011	0018	0023	0031	0038	0044	0058	0072	
Max. Applicable Motor Capacity <sup>1</sup>	HP	Normal Duty	1	2	3	3	5	7.5	10	15	20	25	30	40	50
		Heavy Duty	0.75	2	3	3	5	5	10	10	15	20	30	30	40
Input Rated Input Current <sup>2</sup>	A	Normal Duty	2.1	4.3	5.9	8.1	9.4	14	20	24	38	51	60	58	71
		Heavy Duty	1.8	3.2	4.4	6	8.2	10.4	15	20	29	41	51	43	58
Output Rated Output Capacity <sup>4</sup>	kVA	Normal Duty <sup>5</sup>	1.6	3.1	4.1	5.3	6.7	8.5	13.3	17.5	24	29	34	44	55
		Heavy Duty	1.4 <sup>6</sup>	2.6 <sup>6</sup>	3.7 <sup>6</sup>	4.2 <sup>6</sup>	5.5 <sup>6</sup>	7 <sup>6</sup>	11.3 <sup>6</sup>	13.7 <sup>6</sup>	18.3 <sup>6</sup>	24 <sup>6</sup>	30 <sup>6</sup>	34 <sup>6</sup>	48 <sup>6</sup>
Output Rated Output Current	A	Normal Duty <sup>5</sup>	2.1	4.1	5.4	6.9	8.8	11.1	17.5	23	31	38	44	58	72
		Heavy Duty	1.8 <sup>6</sup>	3.4 <sup>6</sup>	4.8 <sup>6</sup>	5.5 <sup>6</sup>	7.2 <sup>6</sup>	9.2 <sup>6</sup>	14.8 <sup>6</sup>	18 <sup>6</sup>	24 <sup>6</sup>	31 <sup>6</sup>	39 <sup>6</sup>	45 <sup>6</sup>	60 <sup>6</sup>
Output Overload Tolerance		Normal Duty Rating: 120% of rated output current for 60 sec. Heavy Duty Rating: 150% of rated output current for 60 sec. (Derating may be required for repetitive loads)													
Output Carrier Frequency (User Adjustable)		2 to 15 kHz													
Output Max. Output Voltage		Three-phase 380 to 480 V (relative to input voltage)													
Output Max. Output Frequency		400 Hz													
Power Rated Voltage/Rated Frequency		Three-phase 380 to 480 Vac 50/60 Hz 510 to 680 Vdc <sup>3</sup>													
Power Allowable Voltage Fluctuation		-15% to +10%													
Power Allowable Frequency Fluctuation		±5%													
Power Braking Transistor		Included													
Power Fan		No fan					With fan								
Power DC Link Choke		External Option												Included	
Power Power Supply	kVA	Normal Duty	2.3	4.3	6.1	8.1	10	14.5	19.4	28.4	37.5	46.6	54.9	53	64.9
		Heavy Duty	1.4	2.3	4.3	6.1	8.1	10	14.6	19.2	28.4	37.5	46.6	39.3	53

Model	CIMR-AU4A	0088	0103	0139	0165	0208	0250	0296	0362	0414	0515	0675	0930	1200		
Max. Applicable Motor Capacity <sup>1</sup>	HP	Normal Duty	60	75	100	125	150	200	250	300	350	450	600	800	1000	
		Heavy Duty	60	60	75	100	150	150	200	250	300	350	500	700	900	
Input Rated Input Current <sup>2</sup>	A	Normal Duty	86	105	142	170	207	248	300	346	410	465	657	922	1158	
		Heavy Duty	71	86	105	142	170	207	248	300	346	410	584	830	1031	
Output Rated Output Capacity <sup>4</sup>	kVA	Normal Duty <sup>5</sup>	67	78	106	126	159	191	226	276	316	392	514	709	915	
		Heavy Duty	57 <sup>6</sup>	69 <sup>6</sup>	85 <sup>6</sup>	114 <sup>7</sup>	137 <sup>7</sup>	165 <sup>7</sup>	198 <sup>7</sup>	232 <sup>7</sup>	282 <sup>5</sup>	343 <sup>5</sup>	461 <sup>5</sup>	617 <sup>5</sup>	831 <sup>5</sup>	
Output Rated Output Current	A	Normal Duty <sup>5</sup>	88	103	139	165	208	250	296	362	414	515	675	930	1200	
		Heavy Duty	75 <sup>6</sup>	91 <sup>6</sup>	112 <sup>6</sup>	150 <sup>7</sup>	180 <sup>7</sup>	216 <sup>7</sup>	260 <sup>7</sup>	304 <sup>7</sup>	370 <sup>5</sup>	450 <sup>5</sup>	605 <sup>5</sup>	810 <sup>5</sup>	1090 <sup>5</sup>	
Output Overload Tolerance		Normal Duty Rating: 120% of rated output current for 60 sec. Heavy Duty Rating: 150% of rated output current for 60 sec. (Derating may be required for repetitive loads)														
Output Carrier Frequency (User Adjustable)		2 to 15 kHz			2 to 10 kHz						2 to 5 kHz					
Output Max. Output Voltage		Three-phase 380 to 480 V (relative to input voltage)														
Output Max. Output Frequency		400 Hz (user-set)														
Power Rated Voltage/Rated Frequency		Three-phase 380 to 480 Vac 50/60 Hz 510 to 680 Vdc <sup>3</sup>														
Power Allowable Voltage Fluctuation		-15% to +10%														
Power Allowable Frequency Fluctuation		±5%														
Power Braking Transistor		External Option														
Power Fan		With fan														
Power DC Link Choke		Included														
Power Power Supply	kVA	Normal Duty	78.6	96	130	156	189	227	274	316	375	425	601	843	601	
		Heavy Duty	64.9	78.6	96	130	155	189	227	274	316	375	534	759	508	

\*1. The motor capacity (HP) refers to a NEC rated 4-pole motor. The rated output current of the drive output amps should be equal to or greater than the motor current. Select the appropriate capacity drive if operating the motor continuously above motor nameplate current.

\*2. Assumes operation at the rated output current. Input current rating varies depending on the power supply transformer, input reactor, wiring connections, and power supply impedance.

\*3. DC is not available for UL/CE standards.

\*4. Rated motor capacity is calculated with a rated output voltage of 460V.

\*5. Carrier frequency is set to 2 kHz. Current derating is required in order to raise the carrier frequency.

\*6. Carrier frequency can be increased to 8 kHz while keeping this current derating. Higher carrier frequency settings require derating.

\*7. Carrier frequency can be increased to 5 kHz while keeping this current derating. Higher carrier frequency settings require derating.

# Specifications

## 600V Class

Model	CIMR-AU5A		0003	0004	0006	0009	0011	0017	0022	0027	0032	
Max. Applicable Motor Capacity <sup>1</sup>	HP	Normal Duty	2	3	5	7.5	10	15	20	25	30	
		Heavy Duty	1	2	3	5	7.5	10	15	20	25	
Input	Rated Input Current <sup>2</sup>	A	Normal Duty	3.6	5.1	8.3	12	16	23	31	38	45
			Heavy Duty	1.9	3.6	5.1	8.3	12	16	23	31	38
Output	Rated Output Capacity <sup>3</sup>	kVA	Normal Duty <sup>4</sup>	2.7	3.9	6.1	9	11	17	22	27	32
			Heavy Duty	1.7 <sup>5</sup>	3.5 <sup>5</sup>	4.1 <sup>5</sup>	6.3 <sup>5</sup>	9.8 <sup>5</sup>	12 <sup>5</sup>	17 <sup>5</sup>	22 <sup>5</sup>	27 <sup>5</sup>
	Rated Output Current	A	Normal Duty <sup>4</sup>	2.7	3.9	6.1	9	11	17	22	27	32
			Heavy Duty	1.7 <sup>5</sup>	3.5 <sup>5</sup>	4.1 <sup>5</sup>	6.3 <sup>5</sup>	9.8 <sup>5</sup>	12 <sup>5</sup>	17 <sup>5</sup>	22 <sup>5</sup>	27 <sup>5</sup>
	Overload Tolerance		Normal Duty Rating: 120% of rated output current for 60 sec. Heavy Duty Rating: 150% of rated output current for 60 sec. (Derating may be required for applications that start and stop frequently)									
	Carrier Frequency		2 to 15 kHz									
Max. Output Voltage		Three-phase: 500 to 600 V (proportional to input voltage)										
Max. Output Frequency		400 Hz										
Power	Rated Voltage/Rated Frequency		Three-phase 500 to 600 Vac 50/60 Hz									
	Allowable Voltage Fluctuation		-10 (-15) to +10%									
	Allowable Frequency Fluctuation		±5%									
	Braking Transistor		Included									
	Fan		No fan					With fan				
	DC Link Choke		Included									
	Power Supply	kVA	Normal Duty	4.1	5.8	9.5	14	18	26	35	43	51
Heavy Duty			2.2	4.1	5.8	9.5	14	18	26	35	43	

Model	CIMR-AU5A		0041	0052	0062	0077	0099	0125	0145	0192	0242	
Max. Applicable Motor Capacity <sup>1</sup>	HP	Normal Duty	40	50	60	75	100	125	150	200	250	
		Heavy Duty	30	40	50	60	75	100	125	150	200	
Input	Rated Input Current <sup>2</sup>	A	Normal Duty	41	52	62	77	99	125	145	192	242
			Heavy Duty	32	41	52	62	77	100	130	172	200
Output	Rated Output Capacity <sup>3</sup>	kVA	Normal Duty <sup>4</sup>	41	52	62	77	99				
			Heavy Duty	32 <sup>5</sup>	41 <sup>5</sup>	52 <sup>5</sup>	62 <sup>5</sup>	77 <sup>5</sup>				
	Rated Output Current	A	Normal Duty <sup>4</sup>	41	52	62	77	99				
			Heavy Duty	32 <sup>5</sup>	41 <sup>5</sup>	52 <sup>5</sup>	62 <sup>5</sup>	77 <sup>5</sup>				
	Overload Tolerance		Normal Duty Rating: 120% of rated output current for 60 sec. Heavy Duty Rating: 150% of rated output current for 60 sec. (Derating may be required for applications that start and stop frequently)									
	Carrier Frequency		2 to 15 kHz									
Max. Output Voltage		Three-phase: 500 to 600 V (proportional to input voltage)										
Max. Output Frequency		400 Hz (user-set)										
Power	Rated Voltage/Rated Frequency		Three-phase 500 to 600 Vac 50/60 Hz									
	Allowable Voltage Fluctuation		-10 (-15) to +10%									
	Allowable Frequency Fluctuation		±5%									
	Braking Transistor		Data not available									
	Fan		Data not available									
	DC Link Choke		Data not available									
	Power Supply	kVA	Normal Duty	50	62	75	91	123				
Heavy Duty			38	50	62	75	91					

\*1. The motor capacity (HP) refers to a NEC rated 4-pole motor. The rated output current of the drive output amps should be equal to or greater than the motor current. Select the appropriate capacity drive if operating the motor continuously above motor nameplate current.

\*2. Assumes operation at the rated output current. Input current rating varies depending on the power supply transformer, input reactor, wiring connections, and power supply impedance.

\*3. Rated motor capacity is calculated with a rated output voltage of 575V.

\*4. Carrier frequency is set to 2 kHz. Current derating is required to raise the carrier frequency.

\*5. Carrier frequency can be increased to 8 kHz while keeping this current derating. Higher carrier frequency settings require derating.

\*6. Carrier frequency can be increased to 5 kHz while keeping this current derating. Higher carrier frequency settings require derating.

## Common Specifications

Item		Specifications
Control Characteristics	Control Methods	•V/f Control (V/f) •V/f Control with PG (V/f w/PG) •Open Loop Vector Control (OLV) •Closed Loop Vector Control (CLV) •Open Loop Vector Control for PM (OLV/PM) •Advanced Open Loop Vector Control for PM (AOLV/PM) •Closed Loop Vector Control for PM (CLV/PM)
	Frequency Control Range	0.01 to 400 Hz (up to 1000 Hz is available with optional software)
	Frequency Accuracy (Temperature Fluctuation)	Digital input: within ±0.01% of the max output frequency (-10 to +40 °C) Analog input: within ±0.1% of the max output frequency (25 °C ±10 °C)
	Frequency Setting Resolution	Digital inputs: 0.01 Hz Analog inputs: 1/2048 of the maximum output frequency setting (11 bit plus sign)
	Output Frequency Resolution	0.001 Hz
	Frequency Setting Methods	-10 to +10 V, 0 to +10 V, 4 to 20 mA, Pulse Train Input
	Starting Torque <1>	V/f, V/f w/PG: 150% at 3 Hz OLV: 200% at 0.3 Hz CLV, AOLV/PM, CLV/PM: 200% at 0 r/min OLV/PM: 100% at 5% speed
	Speed Control Range <1>	V/f, V/f w/PG: 1:40 OLV: 1:200 CLV, CLV/PM: 1:1500 OLV/PM: 1:20 AOLV/PM: 1:100
	Speed Control Accuracy <1>	OLV: ±0.2% (25 °C ±10 °C) CLV: ±0.01% (25 °C ±10 °C)
	Speed Response <1>	OLV, OLV/PM, AOLV/PM: 10 Hz CLV, CLV/PM: 50 Hz
	Torque Limit	Separate limits in four quadrants (available in OLV, CLV, AOLV/PM, CLV/PM)
	Accel/Decel Time	0.0 to 6000.0 s (4 selectable combinations of independent acceleration and deceleration settings)
	Braking Torque	Approx. 20% (approx. 125% when using braking resistor) <2> • Short-time decel torque <3> : over 100% for 0.5/ 1.0 HP motors, over 50% for 2.0 HP motors, and over 20% for 3.0 HP and above motors <4> (overexcitation braking/High Slip Braking: approx. 40%). • Continuous regenerative torque: approx. 20% <5> (approx. 125% with dynamic braking resistor option <6> : 10% ED, 10s).
	Braking Transistor	Models 2A0004 to 2A0138, 4A0002 to 4A0072, and 5A0003 to 5A0032 have a built-in braking transistor.
	V/f Characteristics	User-selected programs and V/f preset patterns possible
Main Control Functions	Torque Control, Droop Control, Speed/torque Control Switching, Feed Forward Control, Zero Servo Function, Momentary Power Loss Ride-Thru, Speed Search, Overtorque/Undertorque Detection, Torque Limit, 17 Step Speed (max), Accel/deccl Switch, S-curve Accel/deccl, 3-wire Sequence, Auto-tuning (rotational, stationary tuning), Dwell, Cooling Fan on/off Switch, Slip Compensation, Torque Compensation, Frequency Jump, Upper/lower Limits for Frequency Reference, DC Injection Braking at Start and Stop, Overexcitation Braking, High Slip Braking, PID Control (with sleep function), Energy Saving Control, Modbus Comm. (RS-422/485 max, 115.2 kbps), Fault Restart, Application Presets, DriveWorksEZ (customized function), Removable Terminal Block with Parameter Backup Function, Online Tuning, KEB, Overexcitation Deceleration, Inertia (ASR) Tuning, Overvoltage Suppression, High Frequency Injection.	
Protection Function	Motor Protection	Electronic thermal overload relay
	Momentary Overcurrent Protection	Drive stops when output current exceeds 200% of Heavy Duty Rating
	Overload Protection	Drive stops after 60 s at 150% of rated Heavy Duty output current <5>
	Overvoltage Protection	240V class: Faults when DC bus voltage exceeds approx. 410 V; 480V class: Faults when DC bus voltage exceeds approx. 820 V; 600V class: Faults when DC bus voltage exceeds approx. 1040 V.
	Undervoltage Protection	240V class: Faults when DC bus voltage falls below approx. 190 V; 480V class: Faults when DC bus voltage falls below approx. 380 V; 600V class: Faults when DC bus voltage falls below approx. 475 V.
	Momentary Power Loss Ride-Thru	Stops modulating after 15 ms or longer power loss <6>. Resumes operation if power loss is less than 2 s (standard) <7>
	Heatsink Overheat Protection	Thermistor
	Braking Resistance Overheat Protection	Overheat input signal for braking resistor (Optional ERF-type, 3% ED)
	Stall Prevention	Stall Prevention is available during acceleration, deceleration, and during run.
	Ground Fault Protection	Electronic circuit protection <8>
Operating Environment	Charge LED	Remains lit until DC bus voltage falls below 50 V
	Area of Use	Indoors
	Ambient Temperature	-10 to +50°C (Chassis Installation) -10 to +40°C (Chassis with zero side clearance, or Type 1)
	Humidity	95% RH or less (no condensation)
	Storage Temperature	-20 to +60°C (short-term temperature during transportation)
	Altitude	Up to 1000 meters without derating, up to 3000 m with output current and voltage derating
	Shock	10 to 20 Hz: 9.8 m/s <sup>2</sup> 20 to 55 Hz: 5.9 m/s <sup>2</sup> (2A0004 to 2A0211, 4A0002 to 4A0165, and 5A0003 to 5A0032) 2.0 m/s <sup>2</sup> (2A0250 to 2A0415 and 4A0208 to 4A0675)
Standards and Certifications	UL 508C, CSA C22.2, IEC/EN 61508, EN 61800-5-1 <9>	
Protection Design	IP00 enclosure, IP20/NEMA Type 1 enclosure <10>	

- <1> The accuracy of these values depends on motor characteristics, ambient conditions, and drive settings. Specifications may vary with different motors and with changing motor temperature. Contact Yaskawa for consultation.
- <2> Disable Stall Prevention during deceleration (L3-O4 = 0) when using a regenerative converter, a regenerative unit, a braking resistor or the Braking Resistor Unit. The default setting for the Stall Prevention function will interfere with the braking resistor.
- <3> Instantaneous average deceleration torque refers to the torque required to decelerate the motor (uncoupled from the load) from the rated motor speed down to zero in the shortest time.
- <4> Actual specifications may vary depending on motor characteristics.
- <5> Overload protection may be triggered when operating with 150% of the rated output current if the output frequency is less than 6 Hz.
- <6> May be shorter due to load conditions and motor speed.
- <7> A separate Momentary Power Loss Ride-Thru Unit is required for models 2A0004 to 2A0056, 4A0002 to 4A0031, and 5A0003 to 5A0032 if the application needs to continue running for up to 2 seconds during a momentary power loss.
- <8> Ground protection cannot be provided when the impedance of the ground fault path is too low, or when the drive is powered up while a ground fault is present at the output.
- <9> Terminals H1, H2, DM+, and DM- on 600 V class models are designed to the functionality, but are not certified to Insulation coordination: class1.
- <10> Removing the top protective cover or bottom conduit bracket from an IP20/NEMA Type 1 enclosure drive voids NEMA Type 1 protection while maintaining IP20 conformity. This is applicable to models 2A0004 to 2A0211, 4A0002 to 4A0165, and 5A0003 to 5A0032.

# Drive Selection

## Model Number Key

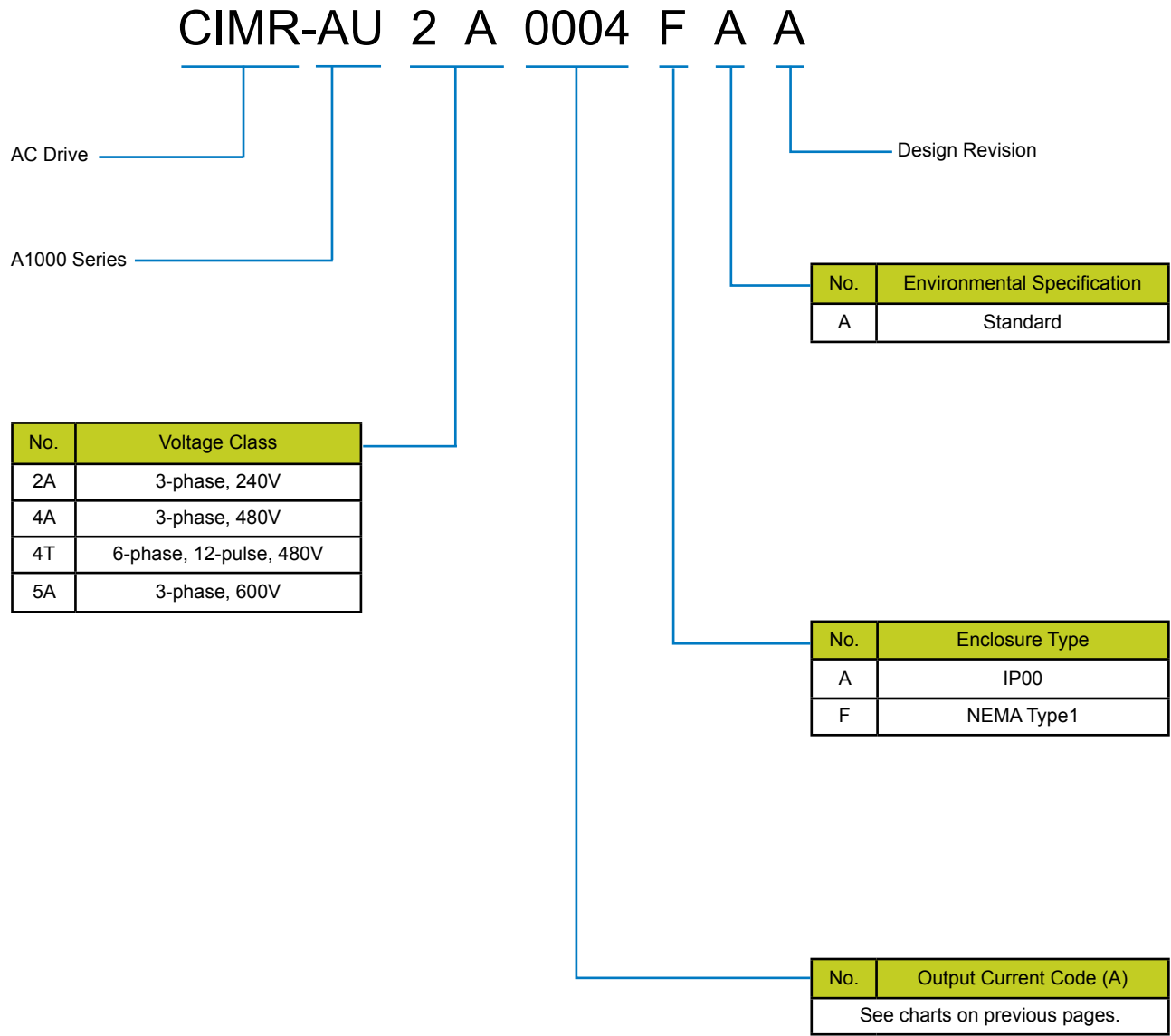

Note: Current codes are equivalent to the Normal Duty current rating.



The A1000 drive can be sized to maximize its capability based on the application type. For applications with little or no overload requirements, size the drive as “Normal Duty.” For applications requiring more than 120% for 60 seconds, size the drive as “Heavy Duty.” See the chart on the next page to select a specific model.

Duty Rating	Normal Duty	Heavy Duty
Overload capacity	120% for 60 sec.	150% for 60 sec.

### Normal Duty Applications



### Heavy Duty Applications

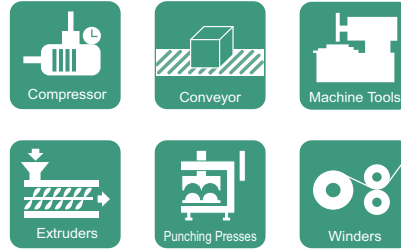

#### Selecting a Drive

For a fan application using a 15 HP motor, select CIMR-AU4A0023 and set it for Normal Duty (C6-01 = 1).

#### Selecting a Drive

For an extruder application using a 15 HP motor, select CIMR-AU4A0031 and set it for Heavy Duty (default).

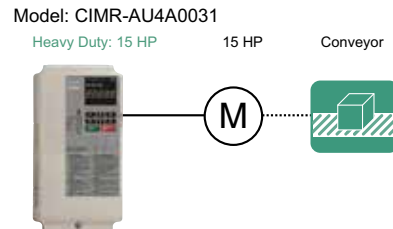
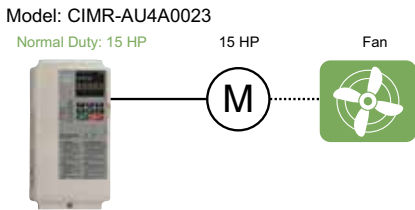

# Drive Selection

HP	Three-Phase 240V				Three-Phase 480V				Three-Phase 600V			
	Normal Duty		Heavy Duty		Normal Duty		Heavy Duty		Normal Duty		Heavy Duty	
	Model CIMR-	Rated Output	Model CIMR-	Rated Output	Model CIMR-	Rated Output	Model CIMR-	Rated Output	Model CIMR-	Rated Output	Model CIMR-	Rated Output
0.75	AU2A0004	3.5 A	AU2A0004	3.2 A	AU4A0002	2.1 A	AU4A0002	1.8 A			AU5A0003	1.7 A
1			AU2A0006	5 A					AU5A0003	2.7 A		
1.5	AU2A0006	6 A					AU4A0004	3.4 A				
2	AU2A0008	8 A	AU2A0008	6.9 A	AU4A0004	4.1 A					AU5A0004	3.5 A
			AU2A0010	8 A								
3	AU2A0010	9.6 A	AU2A0012	11 A	AU4A0005	5.4 A	AU4A0005	4.8 A	AU5A0004	3.9 A	AU5A0006	4.1 A
	AU2A0012	12 A	AU2A0018	14 A	AU4A0007	6.9 A	AU4A0007	5.5 A				
5	AU2A0018	17.5 A	AU2A0021	17.5 A	AU4A0009	8.8 A	AU4A0009	7.2 A	AU5A0006	6.1 A	AU5A0009	6.3 A
							AU4A0011	9.2 A				
7.5	AU2A0021	21 A	AU2A0030	25 A	AU4A0011	11.1 A			AU5A0009	9 A	AU5A0011	9.8 A
							AU4A0018	14.8 A				
10	AU2A0030	30 A	AU2A0040	33 A	AU4A0018	17.5 A	AU4A0023	18 A	AU5A0011	11 A	AU5A0017	12.5 A
15	AU2A0040	40 A	AU2A0056	47 A	AU4A0023	23 A	AU4A0031	24 A	AU5A0017	17 A	AU5A0022	17 A
20	AU2A0056	56 A	AU2A0069	60 A	AU4A0031	31 A	AU4A0038	31 A	AU5A0022	22 A	AU5A0027	22 A
25	AU2A0069	69 A	AU2A0081	75 A	AU4A0038	38 A	AU4A0044	39 A	AU5A0027	27 A	AU5A0032	27 A
30	AU2A0081	81 A	AU2A0110	85 A	AU4A0044	44 A	AU4A0058	45 A	AU5A0032	32 A	AU5A0041	32 A
40	AU2A0110	110 A	AU2A0138	115 A	AU4A0058	58 A	AU4A0072	60 A	AU5A0041	41 A	AU5A0052	41 A
50	AU2A0138	138 A	AU2A0169	145 A	AU4A0072	72 A	AU4A0088	75 A	AU5A0052	52 A	AU5A0062	52 A
60	AU2A0169	169 A	AU2A0211	180 A	AU4A0088	88 A	AU4A0103	91 A	AU5A0062	62 A	AU5A0077	62 A
75	AU2A0211	211 A	AU2A0250	215 A	AU4A0103	103 A	AU4A0139	112 A	AU5A0077	77 A	AU5A0099	77 A
100	AU2A0250	250 A	AU2A0312	283 A	AU4A0139	139 A	AU4A0165	150 A	AU5A0099	99 A	AU5A0125	100 A
125	AU2A0312	312 A	AU2A0360	346 A	AU4A0165	165 A	AU4A0208	180 A	AU5A0125	125 A	AU5A0145	130 A
150	AU2A0360	360 A	AU2A0415	415 A	AU4A0208	208 A	AU4A0250	216 A	AU5A0145	145 A		
175	AU2A0415	415 A									AU5A0192	172 A
200					AU4A0250	250 A	AU4A0296	260 A	AU5A0192	192 A		
250					AU4A0296	296 A	AU4A0362	304 A	AU5A0242	242 A		
300					AU4A0362	362 A	AU4A0414	370 A				
350					AU4A0414	414 A	AU4A0515	450 A				
400												
450					AU4A0515	515 A	AU4A0675	605 A				
500												
550					AU4A0675	675 A						
600							AU4A0930	810 A				
700												
750					AU4A0930	930 A						
800							AU4A1200	1090 A				
900												
1000					AU4A1200	1200 A						

# Control Accessories Selection

## Control Accessories

### I/O and Communication Modules

Type	Name	Model	Function
I/O Expansion Cards	Analog input	AI-A3	<ul style="list-style-type: none"> <li>Allows high precision, high resolution analog reference input</li> <li>Input channels: 3</li> <li>Voltage input: -10 to 10 Vdc (20 kΩ), 13-bit signed</li> <li>Current input: 4 to 20 mA or 0 to 20 mA (250 Ω), 12 bit</li> </ul>
	Analog monitor	AO-A3	<ul style="list-style-type: none"> <li>Provides extra multi-function analog output terminals</li> <li>Output channels: 2</li> <li>Output voltage: -10 to 10 V, 11 bit (signed)</li> </ul>
	Digital Input	DI-A3	<ul style="list-style-type: none"> <li>Sets the frequency reference by digital inputs</li> <li>Input channels: 16 (including SET signal and SIGN signal)</li> <li>Input signal type: BCD 16-bit (4-digit), 12-bit (3-digit), 8 bit (2-digit)</li> <li>Input signal: 24 Vdc, 8 mA</li> </ul>
	Digital output	DO-A3	<ul style="list-style-type: none"> <li>Provides extra insulated multi-function digital outputs</li> <li>Photocoupler relays: 6 (48 V, up to 50 mA)</li> <li>Contact relays: 2 (250 Vac/up to 1 A, 30 Vdc/up to 1 A)</li> </ul>
Drive Mounted Option Cards Feedback Cards	Line Driver Encoder interface	PG-X3	<ul style="list-style-type: none"> <li>For speed feedback input by connecting a motor encoder</li> <li>A QUAD B, and Z output matches RS-422 level, line driver, 300 kHz max</li> <li>Encoder power supply: 5 V or 12 V, max current 200 mA</li> </ul>
	Complimentary Encoder interface	PG-B3	<ul style="list-style-type: none"> <li>For speed feedback input by connecting a motor encoder</li> <li>A QUAD B, and Z output, HTL encoder connection, 50 kHz max</li> <li>Output: open collector 24 V max. 30 mA</li> <li>Encoder power supply: 12 V, max current 200 mA</li> </ul>
	Resolver Interface	PG-RT3	For speed feedback
Communication Cards	EtherNet/IP	SI-EN3	Connects to an EtherNet/IP network
	Modbus TCP/IP	SI-EM3	Connects to a Modbus TCP/IP network
	DeviceNet	SI-N3	Connects to a DeviceNet network
	PROFIBUS-DP	SI-P3	Connects to a PROFIBUS-DP network
	MECHATROLINK-II	SI-T3	Connects to a MECHATROLINK-II network.
	PROFINET	SI-EP3	Connects to a PROFINET network
	EtherCAT	SI-ES3	Connects to a EtherCAT network
	Metasys N2 / Apogee FLN (P1)	SI-J3	Connects to a Metasys N2 / Apogee FLN (P1) network
	BACnet	SI-B3	Connects to a BACnet network
	LonWorks	SI-W3	Connects to a LonWorks network

Note: When using configuration software installed in a drive on various field networks, a file is required to connect the software to the drive.

\* Consult factory for availability

### 24VDC Auxiliary Control Power Input

The 24VDC auxiliary control power input maintains drive control circuit power in the event of a main power outage. The control circuit keeps the network communications and I/O data operational in the event of a power outage. It supplies external power to the control circuit only.

Drive Model	Part No.
240V Class	PS-A10L
480V and 600V Class	PS-A10H

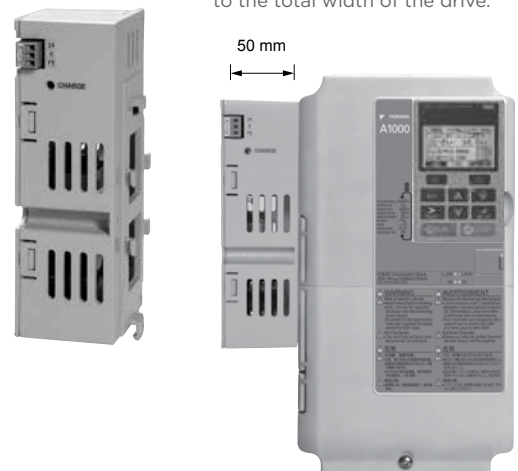

# Control Accessories Selection

## Operator Interfaces

The A1000 includes a multi-language LCD interface as standard. A separately sold LED version is also available.

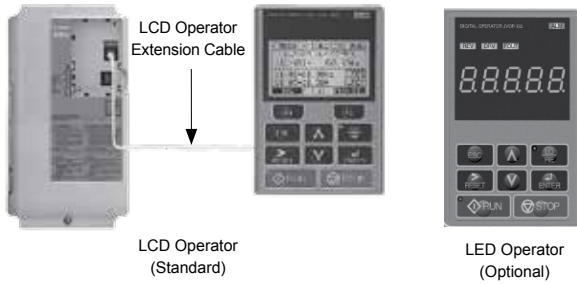

### Dimensions (inches)

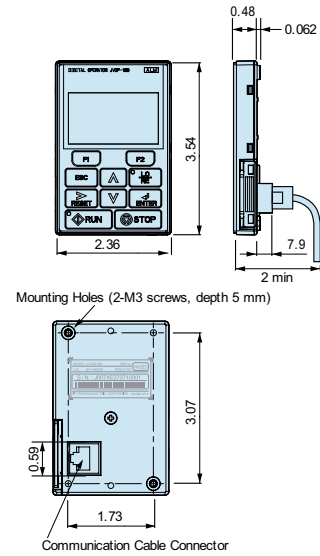

### Operator

Type	Part Number
LCD	JVOP-180 (Standard)
LED	JVOP-182 (Optional)

### Operator Extension Cables

Part Number	Description
UWR0051	3 ft Extension Cable
UWR0052	10 ft Extension Cable

For remote installation (e.g. cabinet door), use one of the following membrane kits.

Part Number	Item	Installation
UUX000526 (Blank Membrane)		
UUX000527 (Yaskawa Logo Membrane)		

## USB Interface Cable (for direct connection between the A1000 and a computer)

Requires A1000 USB device driver file, installed as part of DriveWizard® Industrial (SW.DW.30), available at Yaskawa.com

Part Number	Description
UWR-0638	USB Cable, 10 ft, male A-type to male B-type

## USB Copy Unit (for downloading the same configuration to multiple drives)\*

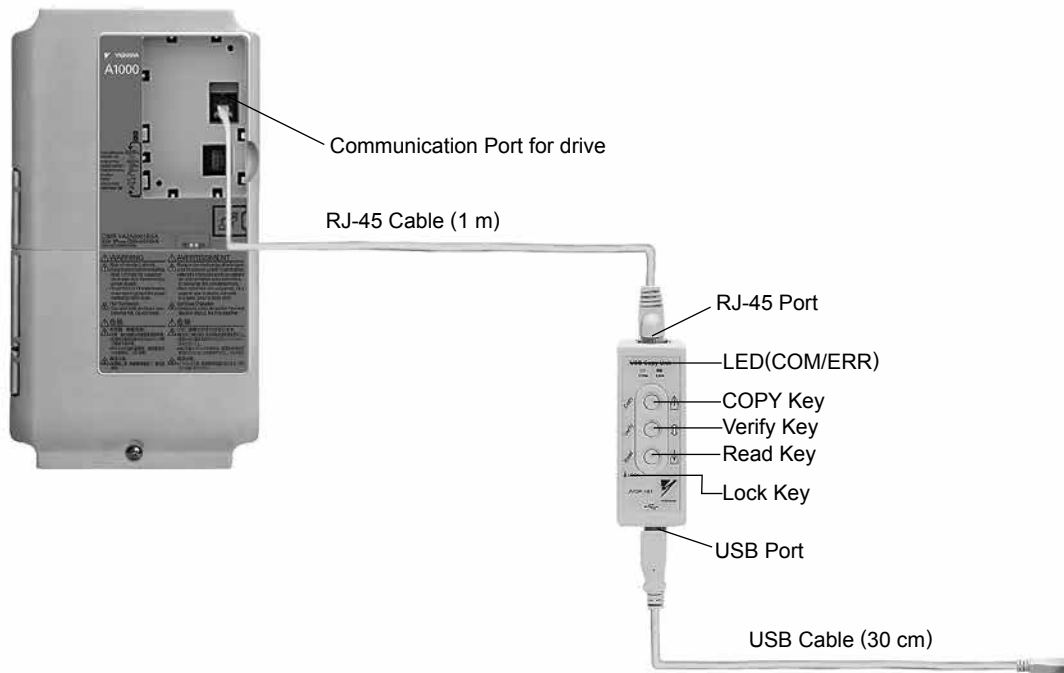

Part Number	Description
JVOP-181	USB Copy Unit with RJ-45 Cable and USB Cable

\* Parameters can only be downloaded to a drive when the voltage class, capacity, control mode, and software version match

# Mechanical Accessories Selection

## Adapter Plates

Adapter Plates are used when replacing an F7 drive with an A1000, or when using an F7 pancake-mounted C1 filter. They consist of a simple plate the height and width (and with holes drilled for the mounting of) an F7 drive, with additional holes to match the mounting dimensions of the smaller A1000. This provides for a means to mount the A1000 drive to the plate; the drive/plate assembly may then be mounted using the old F7 mounting holes.

240V Class		
Model CIMR-AU2A	Part Number EZZ020801□	
0004	A	
0006		
0008		
0010		
0012		
0018		
0021		
0030		
0040		B
0056		C
0069	E	
0081		
0110	Not Required	
0138		
0169	F	
0211		
0250	L	
0312		
0360	M	
0415	N	

480V Class		
Model CIMR-AU4A	Part Number EZZ020801□	
0002	A	
0004		
0005		
0007		
0009		
0011		
0018		
0023		B
0031		C
0038		D
0044	E	
0058	G	
0072	Not Required	
0088	H	
0103	J	
0139	Not Required	
0165	K	
0208	L	
0250	M	
0296		
0362	N	
0414	P	
0515	Consult Factory	
0675		
0930	Not Available	
1200		

## NEMA 1 Endcap Kits

This option consists of a top and bottom cover to convert a protected chassis drive to a NEMA 1 enclosed unit. This option DOES NOT provide additional space for mounting auxiliary components (i.e., circuit breaker, input fuses, reactor, etc.)

240V Class	
Model CIMR-AU2A	Part Number
0110 <sup>(1)</sup>	EZZ021136A
0138 <sup>(1)</sup>	EZZ021136B
0169 <sup>(1)</sup>	EZZ021136C
0211 <sup>(1)</sup>	
0250	EZZ021136D
0312	
0360	EZZ021136E

600V Class	
Model CIMR-AU5A	Part Number
0041 <sup>(1)</sup>	EZZ021136G
0052 <sup>(1)</sup>	
0062 <sup>(1)</sup>	EZZ021136C
0077 <sup>(1)</sup>	
0099 <sup>(1)</sup>	
0125	EZZ021136D
0145	
0192	EZZ021136E
0242	

480V Class	
Model CIMR-AU2A	Part Number
0058 <sup>(1)</sup>	EZZ021136F
0072 <sup>(1)</sup>	EZZ021136G
0088 <sup>(1)</sup>	EZZ021136H
0103 <sup>(1)</sup>	
0139 <sup>(1)</sup>	EZZ021136C
0165 <sup>(1)</sup>	
0208	EZZ021136D
0250	EZZ021136E
0296	
0362	UUX000662
0414	
0515	UUX000663
0675	UUX000664
0930 <sup>(2)</sup>	
1200 <sup>(2)</sup>	UUX000664S
0930 <sup>(2)</sup>	
1200 <sup>(2)</sup>	

Notes:

(1) These ratings are already available as NEMA 1 (FAA) drives; the End Cap Kits for these ratings are shown here only for replacement purposes.

(2) UUX000664 is a floor mount base that mounts underneath models 0930 and 1200. UUX000664S is an optional standoff kit which provides 5 in. of clearance between floor and bottom of mounting base.

## External Heatsink Kits

When mounting standard drives with heatsink external (NEMA 1 backside), the following models require a separately sold bracket kit. Larger standard drives include brackets that must be detached from the back and reattached at the midpoint.

When mounting flange drives (models ending in Uxx), a "flange" feature is integral to the design, and therefore these kits are not used.

240V Class	
Model CIMR-AU2A	Part Number EZZ020800□
0004	A
0006	
0008	
0010	
0012	B
0018	
0021	
0030	
0040	
0056	C
0069	D
0081	

480V Class	
Model CIMR-AU4A	Part Number EZZ020800□
0002	A
0004	
0005	
0007	B
0009	
0011	
0018	C
0023	
0031	D
0038	
0044	

240V Class	
Model CIMR-AU5A	Part Number EZZ020800□
0003	A
0004	
0006	B
0009	
0011	C
0017	
0022	D
0027	
0032	

## Capacitor Guards

Capacitor Guards are only required for A1000 IPOO models (those ending in AAA) to prevent exposure of internal components. NEMA 1 models (those ending in FAA) already include these guards as standard. Flange drives (those ending in UAA) do not require cap guards because the backside is protected by other means.

240V Class	
Model CIMR-AU2A	Part Number
0004-0211	Not Required
0250	EZZ021352E
0312	
0360	EZZ021352F
0415	

600V Class	
Model CIMR-AU5A	Part Number
0003-0099	Not Required
0125	EZZ021352E
0145	
0192	EZZ021352F
0242	

480V Class	
Model CIMR-AU2A	Part Number EZZ020801□
0002-0165	Not Required
0208	EZZ021352E
0250	EZZ021352F
0296	
0362	EZZ021352G
0414	
0515	EZZ021352H
0675	
0930	EZZ021352J
1200	

# Power Accessories Selection

## Reactors

Reactors are used either within the DC link circuit of a drive or at the drive's AC input terminals (line reactor). In both cases, the reactor adds impedance which can extend the life of a drive (when used on large power sources with low impedance), and reduce drive induced harmonic currents. In addition, AC reactors can be used at the drive's output terminals (load reactor) to help address a variety of installation challenges such as peak motor voltages that can occur with long motor cables.

For A1000 drives rated up through 30HP (normal duty), either a DC link reactor or AC reactor (or both) may be added. Larger A1000 drives have a DC link reactor as standard.

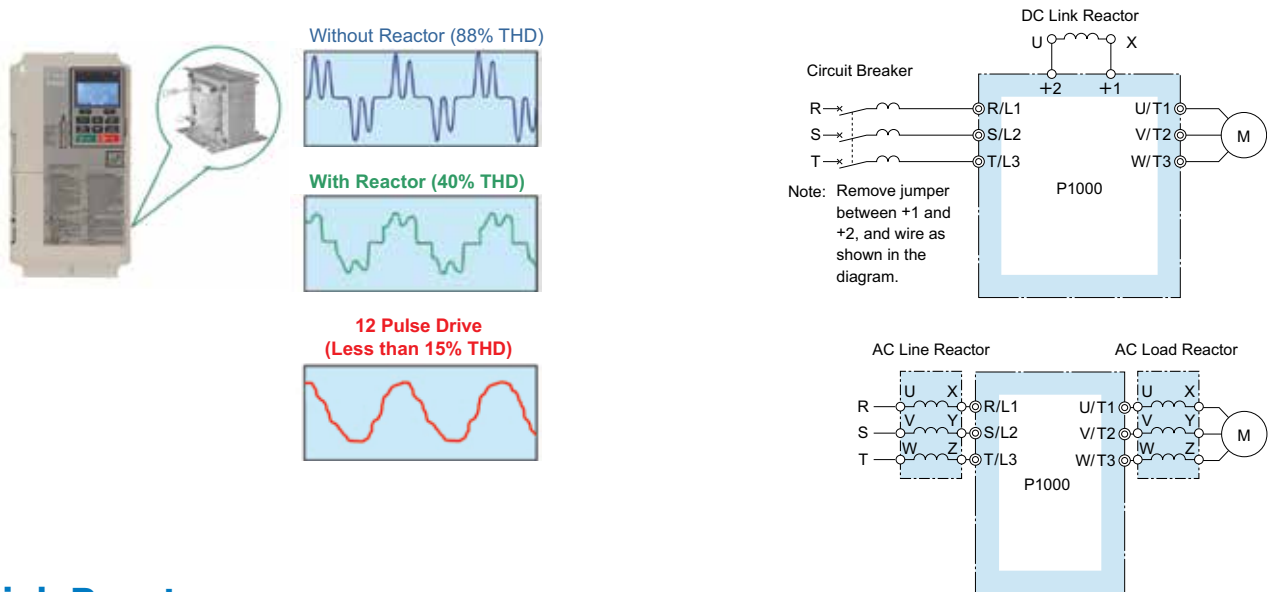

## DC Link Reactors

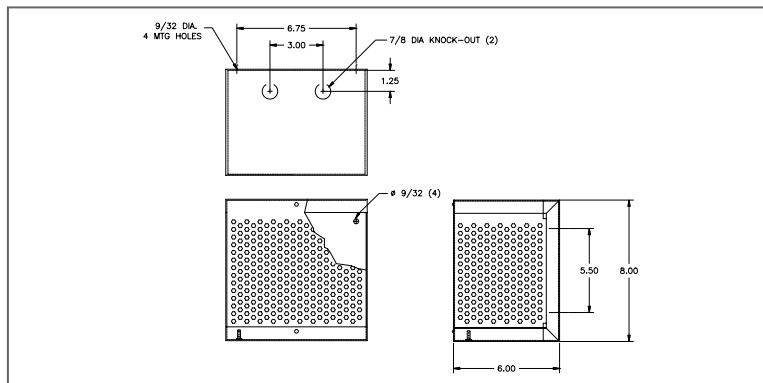

Fig. 1

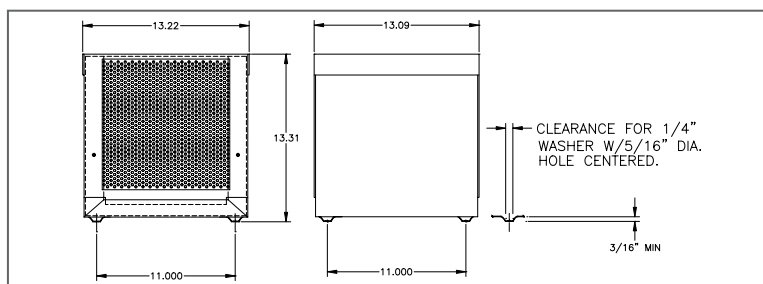

Fig. 2



## DC Link Reactors (continued)

240V Class

HP	Drive Model Number: CIMR-AU2A				3% Enclosed Reactor								
	Normal Duty	Built-in DC Link Reactor	Heavy Duty	Built-in DC Link Reactor	Rated DC Current (A)	Inductance (μH)	Yaskawa Part Number	Dimensions (in.)				Weight (lb)	Watt Loss (W)
								Figure	L	W	H		
0.5	0004	No	0004	No	2	10000	URX000036**	1	2.81	1.73	2.50	1	3
0.75	0004	No	0004	No	4	5000	05P00608-3007**	1	2.81	1.50	2.50	1	4
1	0006	No	0006	No	4	5000	05P00608-3007**	1	2.81	1.50	2.50	1	4
1.5	0006	No	0008	No	9	3220	URX000257	1	8.00	6.00	8.00	9	7
2	0008	No	0008	No	9	3220	URX000257	1	8.00	6.00	8.00	9	7
3	0010	No	0012	No	12	2100	URX000258	1	8.00	6.00	8.00	11	7
5	0018	No	0021	No	18	1375	URX000259	1	8.00	6.00	8.00	11	9
7.5	0021	No	0030	No	25	1000	URX000051**	2	3.81	2.82	4.50	4	12
10	0030	No	0040	No	32	850	URX000261	1	8.00	6.00	8.00	12	11
15	0040	No	0056	No	50	625	URX000262	1	8.00	6.00	8.00	15	18
20	0056	No	0069	No	62	320	URX000264	2	13.22	13.09	13.00	26	17
25	0069	No	0081	No	80	310	0500620-0129**	2	4.63	6.00	4.00	9	20
30	0081	No	0110	Yes*	92	200	URX000266	2	13.22	13.09	13.00	28	19
40 to 175	Built-In												

HP	Drive Model Number: CIMR-AU2A				5% Enclosed Reactor								
	Normal Duty	Built-in DC Link Reactor	Heavy Duty	Built-in DC Link Reactor	Rated DC Current (A)	Inductance (μH)	Yaskawa Part Number	Dimensions (in.)				Weight (lb)	Watt Loss (W)
								Figure	L	W	H		
0.5	0004	No	0004	No	2	20000	0500652-0228**	1	3.00	1.50	2.50	1	4
0.75	0004	No	0004	No	4	12000	URX000207	1	8.00	6.00	8.00	9	5
1	0006	No	0006	No	4	12000	URX000207	1	8.00	6.00	8.00	9	5
1.5	0006	No	0008	No	9	7500	URX000208	1	8.00	6.00	8.00	11	11
2	0008	No	0008	No	9	7500	URX000208	1	8.00	6.00	8.00	11	11
3	0010	No	0012	No	12	4000	URX000209	1	8.00	6.00	8.00	11	11
5	0018	No	0021	No	18	2750	URX000210	1	8.00	6.00	8.00	14	16
7.5	0021	No	0030	No	25	1750	URX000211	1	8.00	6.00	8.00	14	13
10	0030	No	0040	No	32	1620	URX000223	2	13.22	13.09	13.00	28	14
15	0040	No	0056	No	50	970	URX000060**	2	4.63	5.25	5.25	14	19
20	0056	No	0069	No	62	610	URX000213	2	13.22	13.09	13.00	32	20
25	0069	No	0081	No	80	500	URX000069**	2	4.63	7.00	4.00	14	22
30	0081	No	0110*	Yes*	92	600	URX000265	2	13.22	13.09	13.00	41	34
40 to 175	Built-In												

\* 'Large' A1000 models include a built-in 3% DC link reactor. If more than 3% equivalent total reactance is needed, use a 3% AC line reactor on these units.

\*\* Does not include NEMA 1 enclosure.

# Power Accessories Selection

## DC Link Reactors (continued)

480V Class

HP	Drive Model Number: CIMR-AU4A				3% Enclosed Reactor								
	Normal Duty	Built-in DC Link Reactor	Heavy Duty	Built-in DC Link Reactor	Rated DC Current (A)	Inductance (μH)	Yaskawa Part Number	Dimensions (in.)				Weight (lb)	Watt Loss (W)
								Figure	L	W	H		
0.5	0002	No	0002	No	2	50000	URX000215	1	8.00	6.00	8.00	9	5
0.75	0002	No	0002	No	2	20000	05P00652-0228**	1	3.00	1.50	2.50	1	4
1	0002	No	0004	No	2	20000	05P00652-0228**	1	3.00	1.50	2.50	1	4
1.5	0004	No	0004	No	4	15000	URX000217	1	8.00	6.00	8.00	9	6
2	0004	No	0004	No	4	15000	URX000217	1	8.00	6.00	8.00	9	6
3	0005	No	0005	No	9	7500	URX000208	1	8.00	6.00	8.00	11	11
5	0009	No	0011	No	9	7500	URX000208	1	8.00	6.00	8.00	11	11
7.5	0011	No	0018	No	12	4000	URX000209	1	8.00	6.00	8.00	11	11
10	0018	No	0018	No	18	2750	URX000210	1	8.00	6.00	8.00	14	16
15	0023	No	0031	No	25	1750	URX000211	1	8.00	6.00	8.00	14	13
20	0031	No	0038	No	32	1620	URX000223	2	13.22	13.09	13.00	28	14
25	0038	No	0044	No	40	1000	URX000184	1	8.00	6.00	8.00	15	17
30	0044	No	0058	Yes*	50	970	URX000060**	2	4.63	5.25	5.25	14	19
40 to 1000	Built-In												

HP	Drive Model Number: CIMR-AU4A				5% Enclosed Reactor								
	Normal Duty	Built-in DC Link Reactor	Heavy Duty	Built-in DC Link Reactor	Rated DC Current (A)	Inductance (μH)	Yaskawa Part Number	Dimensions (in.)				Weight (lb)	Watt Loss (W)
								Figure	L	W	H		
0.5	0002	No	0002	No	2	50000	URX000215	1	8.00	6.00	8.00	9	5
0.75	0002	No	0002	No	2	50000	URX000215	1	8.00	6.00	8.00	9	5
1	0002	No	0004	No	2	50000	URX000215	1	8.00	6.00	8.00	9	5
1.5	0004	No	0004	No	4	25000	URX000216	1	8.00	6.00	8.00	11	9
2	0004	No	0004	No	4	25000	URX000216	1	8.00	6.00	8.00	11	9
3	0005	No	0005	No	9	11500	URX000218	1	8.00	6.00	8.00	14	16
5	0009	No	0011	No	9	11500	URX000218	1	8.00	6.00	8.00	14	16
7.5	0011	No	0018	No	12	6000	URX000219	1	8.00	6.00	8.00	11	14
10	0018	No	0018	No	18	6000	URX000260	2	13.22	13.09	13.00	31	20
15	0023	No	0031	No	25	4000	URX000224	2	13.22	13.09	13.00	31	16
20	0031	No	0038	No	32	2680	URX000221	2	13.22	13.09	13.00	32	21
25	0038	No	0044	No	40	2500	URX000225	2	13.22	13.09	13.00	39	29
30	0044	No	0058	Yes*	50	2000	URX000263	2	13.22	13.09	13.00	43	30
40 to 1000	Built-In												

\* 'Large' A1000 models include a built-in 3% DC link reactor. If more than 3% equivalent total reactance is needed, use a 3% AC line reactor on these units.

\*\* Does not include NEMA 1 enclosure.

## DC Link Reactors (continued)

600V Class

HP	Drive Model Number: CIMR-AU5A				3% Enclosed Reactor								
	Normal Duty	Built-in DC Link Reactor	Heavy Duty	Built-in DC Link Reactor	Rated DC Current (A)	Inductance (μH)	Yaskawa Part Number	Dimensions (in.)				Weight (lb)	Watt Loss (W)
								Figure	L	W	H		
0.5	0003	No	0003	No	1	60000	URX000039*	1	3.75	2.00	3.25	2	5
0.75	0003	No	0003	No	2	50000	URX000215	1	8.00	6.00	8.00	9	5
1	0003	No	0003	No	2	20000	05P00652-0028**	1	3.00	1.50	2.50	1	4
1.5	0003	No	0004	No	4	15000	URX000217	1	8.00	6.00	8.00	9	6
2	0003	No	0004	No	4	15000	URX000217	1	8.00	6.00	8.00	9	6
3	0004	No	0006	No	4	12000	URX000207	1	8.00	6.00	8.00	9	5
5	0006	No	0009	No	9	7500	URX000208	1	8.00	6.00	8.00	11	11
7.5	0009	No	0011	No	12	4000	URX000209	1	8.00	6.00	8.00	11	11
10	0011	No	0017	No	12	4000	URX000209	1	8.00	6.00	8.00	11	11
15	0017	No	0022	No	18	2750	URX000210	1	8.00	6.00	8.00	14	16
20	0022	No	0027	No	25	1750	URX000211	1	8.00	6.00	8.00	14	13
25	0027	No	0032	No	32	1620	URX000223	2	13.22	13.09	13.00	28	14
30	0032	No	0041	Yes*	40	1000	URX000184	1	8.00	6.00	8.00	15	17
40 to 250	Built-In												

HP	Drive Model Number: CIMR-AU5A				5% Enclosed Reactor								
	Normal Duty	Built-in DC Link Reactor	Heavy Duty	Built-in DC Link Reactor	Rated DC Current (A)	Inductance (μH)	Yaskawa Part Number	Dimensions (in.)				Weight (lb)	Watt Loss (W)
								Figure	L	W	H		
0.5	0003	No	0003	No	1	80000	URX000035**	1	3.75	1.75	3.25	1	4
0.75	0003	No	0003	No	2	50000	URX000215	1	8.00	6.00	8.00	9	5
1	0003	No	0003	No	2	50000	URX000215	1	8.00	6.00	8.00	9	5
1.5	0003	No	0004	No	4	25000	URX000216	1	8.00	6.00	8.00	11	9
2	0003	No	0004	No	4	25000	URX000216	1	8.00	6.00	8.00	11	9
3	0004	No	0006	No	4	25000	URX000216	1	8.00	6.00	8.00	11	9
5	0006	No	0009	No	9	11500	URX000218	1	8.00	6.00	8.00	14	16
7.5	0009	No	0011	No	12	6000	URX000219	1	8.00	6.00	8.00	11	14
10	0011	No	0017	No	18	3750	URX000220	1	8.00	6.00	8.00	15	17
15	0017	No	0022	No	25	4000	URX000224	2	13.22	13.09	13.00	31	16
20	0022	No	0027	No	25	4000	URX000224	2	13.22	13.09	13.00	31	16
25	0027	No	0032	No	32	2680	URX000221	2	13.22	13.09	13.00	32	21
30	0032	No	0041	Yes*	50	2000	URX000263	2	13.22	13.09	13.00	43	30
40 to 250	Built-In												

\*Large A1000 models include a built-in 3% DC link reactor. If more than 3% equivalent total reactance is needed, use a 3% AC line reactor on these units.

\*\* Does not include NEMA 1 enclosure.

# Power Accessories Selection

## AC Line / Load Reactors

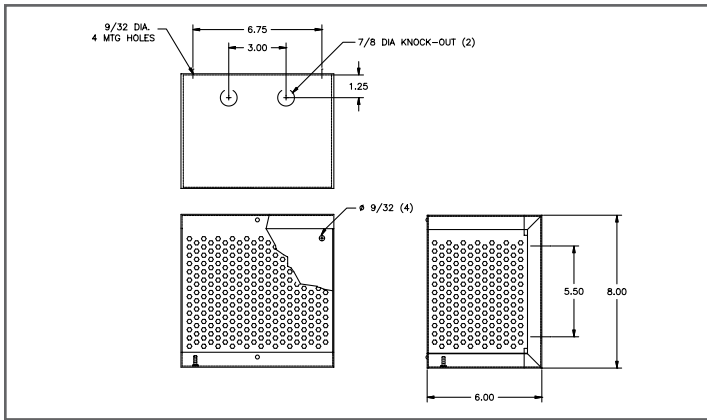

Fig. 1

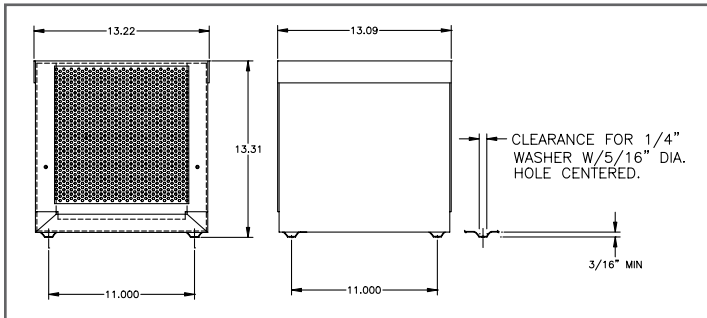

Fig. 2

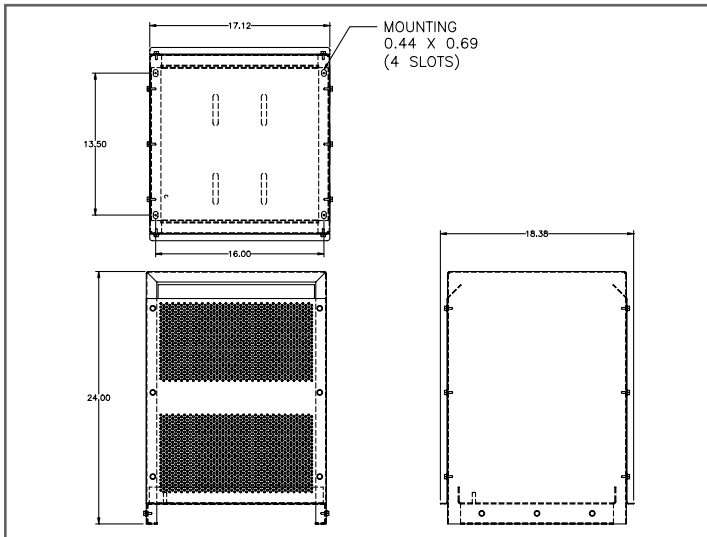

Fig. 3

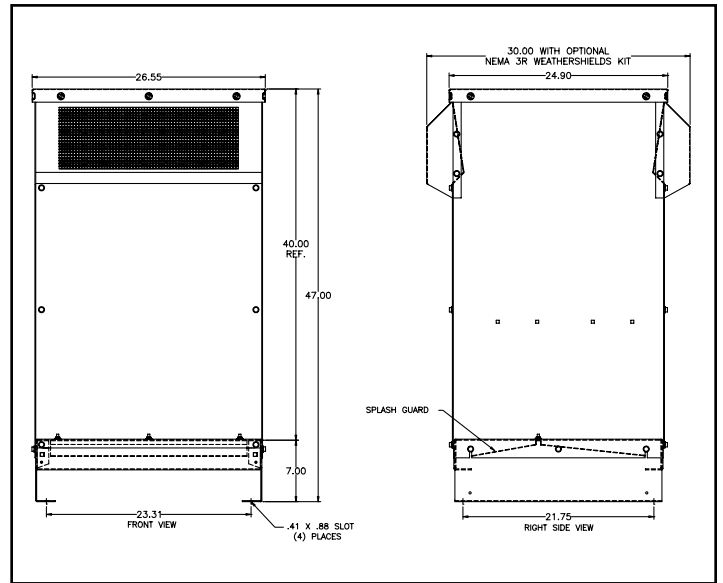

Fig. 4

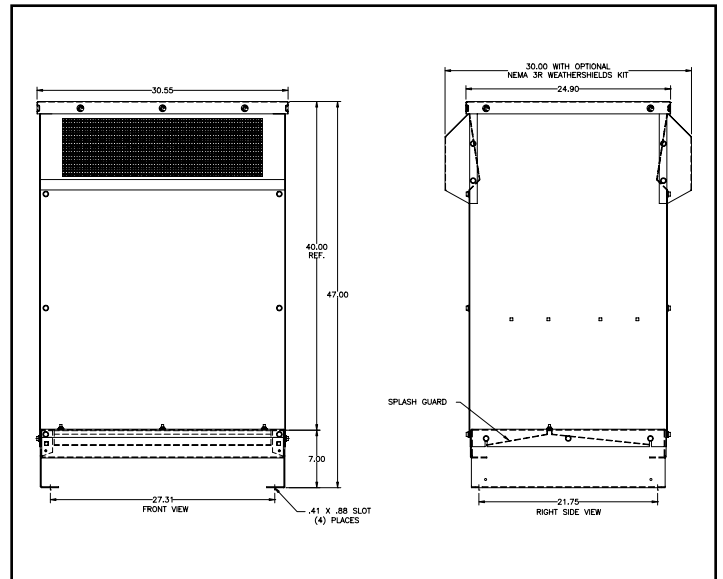

Fig. 5

# AC Line / Load Reactors (continued)

240V Class

HP	Drive Model Number: CIMR-AU2A				Nominal 3% Impedance*								
	Normal Duty	Built-in DC Link Reactor	Heavy Duty	Built-in DC Link Reactor	Reactor Rated Current (A)	Inductance (μH)	Enclosed Yaskawa Part Number	Dimensions (in.)			Weight (lb)	Watt Loss (W)	
								Figure	L	W			H
0.5	0004	No	0004	No	2	6000	URX000243	1	8.00	6.00	8.00	10	10.7
0.75	0004	No	0004	No	4	3000	05P00620-0020		8.00	6.00	8.00	11	14.5
1	0006	No	0006	No	4	3000	05P00620-0020		8.00	6.00	8.00	11	14.5
1.5	0006	No	0008	No	8	1500	05P00620-0027		8.00	6.00	8.00	14	19.5
2	0008	No	0008	No	8	1500	05P00620-0027		8.00	6.00	8.00	14	19.5
3	0010	No	0012	No	12	1250	05P00620-0032		8.00	6.00	8.00	16	26
5	0018	No	0021	No	18	800	05P00620-0036		8.00	6.00	8.00	16	36
7.5	0021	No	0030	No	25	500	05P00620-0041	2	13.22	13.09	13.00	29	48
10	0030	No	0040	No	35	400	05P00620-0046		13.22	13.09	13.00	32	49
15	0040	No	0056	No	45	300	05P00620-0050		13.22	13.09	13.00	41	54
20	0056	No	0069	No	55	250	05P00620-0054		13.22	13.09	13.00	42	64
25	0069	No	0081	No	80	200	05P00620-0058		13.22	13.09	13.00	43	82
30	0081	No	--	--	80	200	05P00620-0058		13.22	13.09	13.00	43	82
30	--	--	0110	Yes	80	200	05P00620-0058		13.22	13.09	13.00	43	82
40	0110	Yes	0138	Yes	100	150	URX000204		13.22	13.09	13.00	47	94
50	0138	Yes	0169	Yes	130	100	05P00620-0066		13.22	13.09	13.00	47	108
60	0169	Yes	0211	Yes	160	75	URX000206		13.22	13.09	13.00	59	116
75	0211	Yes	0250	Yes	250	45	URX000248	13.22	13.09	13.00	65	154	
100	0250	Yes	0312	Yes	250	45	URX000248	13.22	13.09	13.00	65	154	
125	0312	Yes	0360	Yes	320	40	URX000249	3	18.38	16.88	24.00	107	224
150	0360	Yes	0415	Yes	400	30	URX000250		18.38	16.88	24.00	111	231
175	0415	Yes	0415	Yes	500	25	URX000251		18.38	16.88	24.00	111	231

\* Large A1000 chassis have a built-in DC link reactor equivalent to 3% line reactance. 240V ratings are shown with 3% added AC reactance for 6% total.

HP	Drive Model Number: CIMR-AU2A				Nominal 5% Impedance*								
	Normal Duty	Built-in DC Link Reactor	Heavy Duty	Built-in DC Link Reactor	Reactor Rated Current (A)	Inductance (μH)	Enclosed Yaskawa Part Number	Dimensions (in.)			Weight (lb)	Watt Loss (W)	
								Figure	L	W			H
0.5	0004	No	0004	No	2	12000	05P00620-0015	1	8.00	6.00	8.00	11	7.5
0.75	0004	No	0004	No	4	6500	05P00620-0021		8.00	6.00	8.00	11	20
1	0006	No	0006	No	4	6500	05P00620-0021		8.00	6.00	8.00	11	20
1.5	0006	No	0008	No	8	3000	05P00620-0028		8.00	6.00	8.00	15	29
2	0008	No	0008	No	8	3000	05P00620-0028		8.00	6.00	8.00	15	29
3	0010	No	0012	No	12	2500	05P00620-0033		8.00	6.00	8.00	17	31
5	0018	No	0021	No	18	1500	05P00620-0037		8.00	6.00	8.00	15	43
7.5	0021	No	0030	No	25	1200	05P00620-0042	2	13.22	13.09	13.00	32	52
10	0030	No	0040	No	35	800	05P00620-0047		13.22	13.09	13.00	34	54
15	0040	No	0056	No	45	700	05P00620-0051		13.22	13.09	13.00	46	62
20	0056	No	0069	No	55	500	05P00620-0055		13.22	13.09	13.00	45	67
25	0069	No	0081	No	80	400	05P00620-0059		13.22	13.09	13.00	51	86
30	0081	No	--	--	80	400	05P00620-0059		13.22	13.09	13.00	51	86
30	--	--	0110	Yes	80	200	05P00620-0058		13.22	13.09	13.00	43	82
40	0110	Yes	0138	Yes	100	150	URX000204		13.22	13.09	13.00	47	94
50	0138	Yes	0169	Yes	130	100	05P00620-0066		13.22	13.09	13.00	47	108
60	0169	Yes	0211	Yes	160	75	URX000206		13.22	13.09	13.00	59	116
75	0211	Yes	0250	Yes	250	45	URX000248	13.22	13.09	13.00	65	154	
100	0250	Yes	0312	Yes	250	45	URX000248	13.22	13.09	13.00	65	154	
125	0312	Yes	0360	Yes	320	40	URX000249	3	18.38	16.88	24.00	107	224
150	0360	Yes	0415	Yes	400	30	URX000250		18.38	16.88	24.00	111	231
175	0415	Yes	0415	Yes	500	25	URX000251		18.38	16.88	24.00	111	231

\* Large A1000 chassis have a built-in DC link reactor equivalent to 3% line reactance. 240V ratings are shown with 3% added AC reactance for 6% total.

# Power Accessories Selection

## AC Line / Load Reactors (continued)

480V Class

HP	Drive Model Number: CIMR-AU4A				Nominal 3% Impedance*								
	Normal Duty	Built-in DC Link Reactor	Heavy Duty	Built-in DC Link Reactor	Reactor Rated Current (A)	Inductance (μH)	Enclosed Yaskawa Part Number	Dimensions (in.)			Weight (lb)	Watt Loss (W)	
								Figure	L	W			H
0.5	0002	No	0002	No	1	18000	URX000242	1	8.00	6.00	8.00	11	9.6
0.75	0002	No	0002	No	2	12000	05P00620-0015		8.00	6.00	8.00	11	7.5
1	0002	No	0004	No	2	12000	05P00620-0015		8.00	6.00	8.00	11	7.5
1.5	0004	No	0004	No	4	6500	05P00620-0021		8.00	6.00	8.00	11	20
2	0004	No	0004	No	4	6500	05P00620-0021		8.00	6.00	8.00	11	20
3	0005	No	0005	No	8	3000	05P00620-0028		8.00	6.00	8.00	15	29
5	0009	No	0011	No	8	3000	05P00620-0028		8.00	6.00	8.00	15	29
7.5	0011	No	0018	No	12	2500	05P00620-0033		8.00	6.00	8.00	17	31
10	0018	No	0018	No	18	1500	05P00620-0037		8.00	6.00	8.00	19	43
15	0023	No	0031	No	25	1200	05P00620-0042		13.22	13.09	13.00	32	52
20	0031	No	0038	No	35	800	05P00620-0047	13.22	13.09	13.00	34	54	
25	0038	No	0044	No	35	800	05P00620-0047	13.22	13.09	13.00	34	54	
30	0044	No	--	--	45	700	05P00620-0051	13.22	13.09	13.00	46	62	
30	--	--	0058	Yes	45	300	05P00620-0050	13.22	13.09	13.00	41	54	
40	0058	Yes	0072	Yes	55	250	05P00620-0054	13.22	13.09	13.00	42	64	
50	0072	Yes	0088	Yes	80	200	05P00620-0058	13.22	13.09	13.00	43	82	
60	0088	Yes	0088	Yes	80	200	05P00620-0058	13.22	13.09	13.00	43	82	
75	0103	Yes	0103	Yes	100	150	URX000204	13.22	13.09	13.00	47	94	
100	0139	Yes	0165	Yes	130	100	05P00620-0066	13.22	13.09	13.00	47	108	
125	0165	Yes	0165	Yes	160	75	URX000206	13.22	13.09	13.00	59	116	
150	0208	Yes	0208	Yes	200	55	05P00620-0077	13.22	13.09	13.00	56	124	
200	0250	Yes	0250	Yes	250	45	URX000248	13.22	13.09	13.00	65	154	
250	0296	Yes	0362	Yes	320	40	URX000249	3	18.38	16.88	24.00	107	224
300	0362	Yes	0414	Yes	400	30	URX000250		18.38	16.88	24.00	111	231
350	0414	Yes	0515	Yes	500	25	URX000251		18.38	16.88	24.00	120	266
400	0515	Yes	0675	Yes	500	25	URX000251		18.38	16.88	24.00	120	266
450	0675	Yes	0675	Yes	600	20	URX000252	4	26.55	24.90	47.00	264	307
500	0675	Yes	0675	Yes	600	20	URX000252		26.55	24.90	47.00	264	307
600	0675	Yes	0930	Yes	750	15	URX000253	5	30.55	24.90	47.00	299	427
660	0930	Yes	0930	Yes	750	15	URX000253		30.55	24.90	47.00	299	427
700	0930	Yes	0930	Yes	900	13	URX000254		30.55	24.90	47.00	444	860
750	0930	Yes	1200	Yes	900	13	URX000254		30.55	24.90	47.00	444	860
800	1200	Yes	1200	Yes	1000	11	URX000244		30.55	24.90	47.00	479	940
900	1200	Yes	1200	Yes	1200	9	URX000246		30.55	24.90	47.00	584	980
1000	1200	Yes	1200	Yes	1200	9	URX000246		30.55	24.90	47.00	584	980

\* Large A1000 chassis have a built-in DC link reactor equivalent to 3% line reactance. 480V ratings are shown with 1.5% added AC reactance for 4.5% total.

## AC Line / Load Reactors (continued)

480V Class

HP	Drive Model Number: CIMR-AU4A				Nominal 5% Impedance*									
	Normal Duty	Built-in DC Link Reactor	Heavy Duty	Built-in DC Link Reactor	Reactor Rated Current (A)	Inductance (μH)	Enclosed Yaskawa Part Number	Dimensions (in.)			Weight (lb)	Watt Loss (W)		
								Figure	L	W			H	
0.5	0002	No	0002	No	1	36000	URX000241	1	8.00	6.00	8.00	11	11.9	
0.75	0002	No	0002	No	2	20000	05P00620-0016		8.00	6.00	8.00	11	11.3	
1	0002	No	0004	No	2	20000	05P00620-0016		8.00	6.00	8.00	11	11.3	
1.5	0004	No	0004	No	4	12000	05P00620-0023		8.00	6.00	8.00	13	21	
2	0004	No	0004	No	4	12000	05P00620-0023		8.00	6.00	8.00	13	21	
3	0005	No	0005	No	8	7500	URX000226		8.00	6.00	8.00	20	28	
5	0009	No	0011	No	8	5000	05P00620-0029		8.00	6.00	8.00	18	25.3	
7.5	0011	No	0018	No	12	4200	05P00620-0034		8.00	6.00	8.00	25	41	
10	0018	No	0018	No	18	2500	05P00620-0038		2	13.22	13.09	13.00	34	43
15	0023	No	0031	No	25	1800	05P00620-0043	13.22		13.09	13.00	38	61	
20	0031	No	0038	No	35	1200	05P00620-0048	13.22		13.09	13.00	48	54	
25	0038	No	0044	No	35	1200	05P00620-0048	13.22		13.09	13.00	48	54	
30	0044	No	--	--	45	1200	05P00620-0052	13.22		13.09	13.00	57	65	
30	--	--	0058	Yes	45	700	05P00620-0051	13.22		13.09	13.00	46	62	
40	0058	Yes	0072	Yes	55	500	05P00620-0055	13.22		13.09	13.00	45	67	
50	0072	Yes	0088	Yes	80	400	05P00620-0059	13.22		13.09	13.00	51	86	
60	0088	Yes	0088	Yes	80	400	05P00620-0059	13.22		13.09	13.00	51	86	
75	0103	Yes	0103	Yes	100	300	05P00620-0062	13.22		13.09	13.00	55	84	
100	0139	Yes	0165	Yes	130	200	05P00620-0067	13.22		13.09	13.00	61	180	
125	0165	Yes	0165	Yes	160	150	05P00620-0073	13.22		13.09	13.00	68	149	
150	0208	Yes	0208	Yes	200	110	05P00620-0078	13.22		13.09	13.00	72	168	
200	0250	Yes	0250	Yes	250	90	05P00620-0083	3		18.38	16.88	24.00	107	231
250	0296	Yes	0362	Yes	320	75	05P00620-0088			18.38	16.88	24.00	129	264
300	0362	Yes	0414	Yes	400	60	05P00620-0092			18.38	16.88	24.00	145	333
350	0414	Yes	0515	Yes	500	50	05P00620-0096	4		26.55	24.90	47.00	262	340
400	0515	Yes	0675	Yes	500	50	05P00620-0096		26.55	24.90	47.00	262	340	
450	0675	Yes	0675	Yes	600	40	05P00620-0100		26.55	24.90	47.00	319	414	
500	0675	Yes	0675	Yes	600	40	05P00620-0100		26.55	24.90	47.00	319	414	
600	0675	Yes	0930	Yes	750	29	05P00620-0104	5	30.55	24.90	47.00	349	630	
660	0930	Yes	0930	Yes	750	29	05P00620-0104		30.55	24.90	47.00	349	630	
700	0930	Yes	0930	Yes	900	25	URX000255		30.55	24.90	47.00	529	1020	
750	0930	Yes	1200	Yes	900	25	URX000255		30.55	24.90	47.00	529	1020	
800	1200	Yes	1200	Yes	1000	22	URX000245		30.55	24.90	47.00	567	1090	
900	1200	Yes	1200	Yes	1200	19	URX000247		30.55	24.90	47.00	599	1130	
1000	1200	Yes	1200	Yes	1200	19	URX000247		30.55	24.90	47.00	599	1130	

\* Large A1000 chassis have a built-in DC link reactor equivalent to 3% line reactance. 480V ratings are shown with 3% added AC reactance for 6% total.

# Power Accessories Selection

## AC Line / Load Reactors (continued)

600V Class

HP	Drive Model Number: CIMR-AU5A				Nominal 3% Impedance*								
	Normal Duty	Built-in DC Link Reactor	Heavy Duty	Built-in DC Link Reactor	Rated AC Current (A)	Inductance (μH)	Enclosed Yaskawa Part Number	Dimensions (in.)			Weight (lb)	Watt Loss (W)	
								Figure	L	W			H
0.5	0003	No	0003	No	1	36000	URX000241	1	8.00	6.00	8.00	11	11.9
0.75	0003	No	0003	No	2	20000	05P00620-0016		8.00	6.00	8.00	11	11.3
1	0003	No	0003	No	2	20000	05P00620-0016		8.00	6.00	8.00	11	11.3
1.5	0003	No	0004	No	2	20000	05P00620-0016		8.00	6.00	8.00	11	11.3
2	0003	No	0004	No	4	9000	05P00620-0022		8.00	6.00	8.00	12	20
3	0004	No	0006	No	4	9000	05P00620-0022		8.00	6.00	8.00	12	20
5	0006	No	0009	No	8	5000	05P00620-0029		8.00	6.00	8.00	18	25.3
7.5	0009	No	0011	No	12	2500	05P00620-0033		8.00	6.00	8.00	17	31
10	0011	No	0017	No	12	2500	05P00620-0033		8.00	6.00	8.00	17	31
15	0017	No	0022	No	18	1500	05P00620-0037		8.00	6.00	8.00	19	43
20	0022	No	0027	No	25	1200	05P00620-0042	2	13.22	13.09	13.00	32	52
25	0027	No	0032	No	25	1200	05P00620-0042		13.22	13.09	13.00	32	52
30	0032	No	--	--	35	800	05P00620-0047		13.22	13.09	13.00	34	54
30	--	--	0041	Yes	35	400	05P00620-0046		13.22	13.09	13.00	32	49
40	0041	Yes	0052	Yes	45	300	05P00620-0050		13.22	13.09	13.00	41	54
50	0052	Yes	0062	Yes	55	250	05P00620-0054		13.22	13.09	13.00	42	64
60	0062	Yes	0077	Yes	80	200	05P00620-0058		13.22	13.09	13.00	43	82
75	0077	Yes	0099	Yes	80	200	05P00620-0058		13.22	13.09	13.00	43	82
100	0099	Yes	0125	Yes	100	150	URX000204		13.22	13.09	13.00	47	94
125	0125	Yes	0145	Yes	130	100	05P00620-0066		13.22	13.09	13.00	47	108
150	0145	Yes	0192	Yes	160	75	URX000206	13.22	13.09	13.00	59	116	
200	0192	Yes	0242	Yes	200	55	05P00620-0077	13.22	13.09	13.00	56	124	
250	0242	Yes	--	--	250	45	05P00620-0077	13.22	13.09	13.00	65	154	

\* Large A1000 chassis have a built-in DC link reactor equivalent to 3% line reactance. 600V ratings are shown with 1.5% added AC reactance for 4.5% total.



## AC Line / Load Reactors (continued)

600V Class

HP	Drive Model Number: CIMR-AU5A				Nominal 5% Impedance*								
	Normal Duty	Built-in DC Link Reactor	Heavy Duty	Built-in DC Link Reactor	Rated AC Current (A)	Inductance (μH)	Enclosed Yaskawa Part Number	Dimensions (in.)			Weight (lb)	Watt Loss (W)	
								Figure	L	W			H
0.5	0003	No	0003	No	1	18000	URX000242	1	8.00	6.00	8.00	11	9.6
0.75	0003	No	0003	No	2	32000	URX000227		8.00	6.00	8.00	11	16
1	0003	No	0003	No	2	32000	URX000227		8.00	6.00	8.00	11	16
1.5	0003	No	0004	No	2	32000	URX000227		8.00	6.00	8.00	11	16
2	0003	No	0004	No	4	12000	05P00620-0023		8.00	6.00	8.00	13	21
3	0004	No	0006	No	4	12000	05P00620-0023		8.00	6.00	8.00	13	21
5	0006	No	0009	No	8	7500	URX000226		8.00	6.00	8.00	20	28
7.5	0009	No	0011	No	12	4200	05P00620-0034		8.00	6.00	8.00	25	41
10	0011	No	0017	No	12	4200	05P00620-0034		8.00	6.00	8.00	25	41
15	0017	No	0022	No	18	2500	05P00620-0038		2	13.22	13.09	13.00	34
20	0022	No	0027	No	25	1800	05P00620-0043	13.22		13.09	13.00	38	61
25	0027	No	0032	No	25	1800	05P00620-0043	13.22		13.09	13.00	38	61
30	0032	No	--	--	35	1200	05P00620-0048	13.22		13.09	13.00	48	54
30	--	--	0041	Yes	35	800	05P00620-0047	13.22		13.09	13.00	34	54
40	0041	Yes	0052	Yes	45	700	05P00620-0051	13.22		13.09	13.00	46	62
50	0052	Yes	0062	Yes	55	500	05P00620-0055	13.22		13.09	13.00	45	67
60	0062	Yes	0077	Yes	80	400	05P00620-0059	13.22		13.09	13.00	51	86
75	0077	Yes	0099	Yes	80	400	05P00620-0059	13.22		13.09	13.00	51	86
100	0099	Yes	0125	Yes	100	300	05P00620-0062	13.22		13.09	13.00	55	84
125	0125	Yes	0145	Yes	130	200	05P00620-0067	13.22	13.09	13.00	61	180	
150	0145	Yes	0192	Yes	160	150	05P00620-0073	13.22	13.09	13.00	68	149	
200	0192	Yes	0242	Yes	200	110	05P00620-0078	13.22	13.09	13.00	72	168	
250	0242	Yes	--	--	250	90	05P00620-0083	3	18.38	16.88	24.00	107	231

\* Large A1000 chassis have a built-in DC link reactor equivalent to 3% line reactance. 600V ratings are shown with 3% added AC reactance for 6% total.

# Power Accessories Selection

## EMC Filters

EMC filters are used to reduce high frequency noise on the input (line side) conductors to comply with CE (European) directives. In addition, certification of the Functional Safety (Safe Torque Off) feature requires a CE compliant installation.

### Connection Diagram

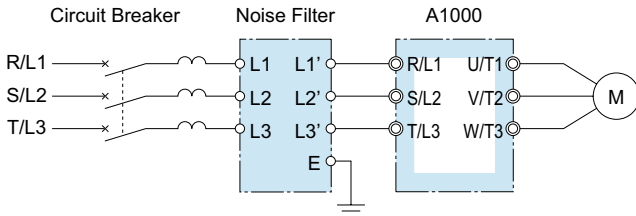

### Manufactured by EPCOS (UL Listed)

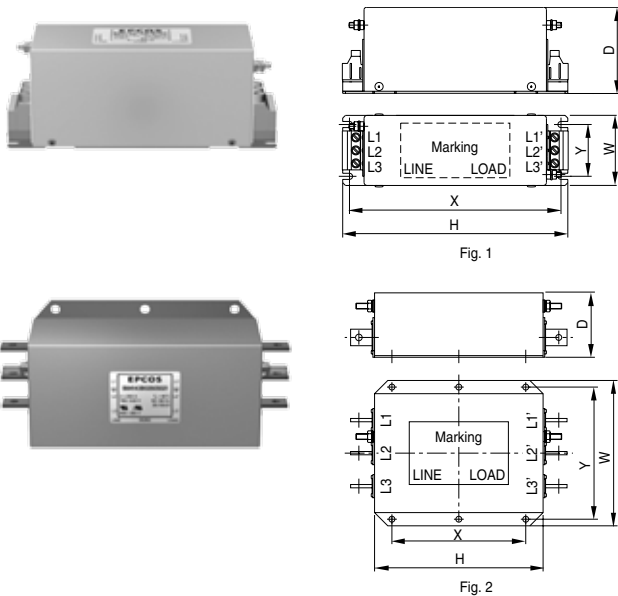

### Manufactured by Schaffner

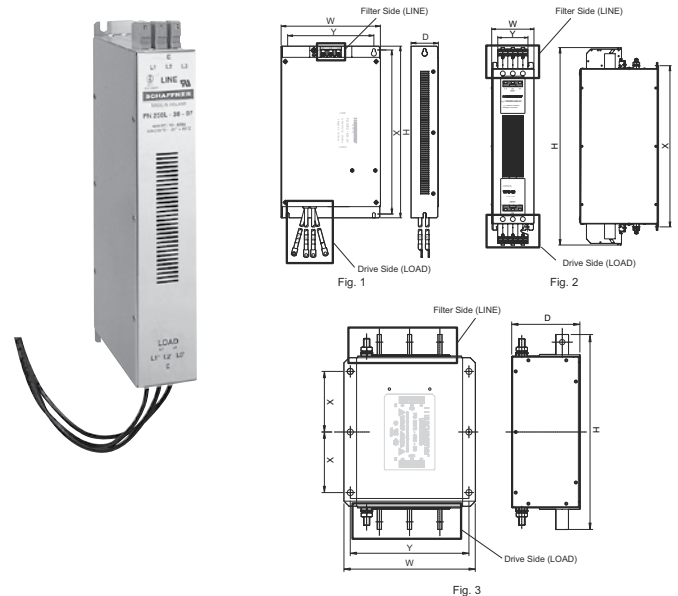

### EPCOS Dimensions

Yaskawa Part Number	Dimensions (in.)					Weight (lb)	Fig.
	W	D	H	X	Y		
UFI000177	2.02	2.48	6.50	1.50	6.10	1.3	1
UFI000178	1.83	2.76	9.09	1.50	8.70	2	1
UFI000179	1.83	3.27	9.09	1.50	8.70	2.4	1
UFI000180	2.28	3.54	10.43	1.38	10.04	3.9	1
UFI000181	2.28	3.54	10.43	1.38	10.04	3.9	1
UFI000182	2.28	5.57	10.43	1.38	10.04	6	1
UFI000183	3.15	5.31	11.42	2.36	10.04	9.3	1
UFI000184	3.54	5.91	11.42	2.56	10.04	10.8	1
UFI000185	3.54	5.91	10.63	2.56	10.04	11.7	1
UFI000186	7.48	4.53	11.81	6.50	9.45	33.1	2
UFI000187	10.24	4.57	11.81	9.25	9.45	46.3	2
UFI000188	10.24	4.57	11.81	9.25	9.45	46.3	2
UFI000189	10.24	4.57	13.78	9.25	11.42	48.5	2
UFI000190	11.81	6.54	13.78	10.83	11.42	61.7	2
UFI000191	11.81	9.84	15.75	10.83	13.39	75	2
UFI000192	15.16	12.60	25.59	13.98	22.05	232	2

### Schaffner Dimensions

Yaskawa Part Number	Dimensions (in.)					Weight (lb)	Fig.
	W	D	H	X	Y		
FS5972-10-07	5.6	1.8	13	4.5	12.3	2.6	1
FS5972-18-07	5.6	1.8	13	4.5	12.3	2.9	1
FS5972-35-07	8.1	2	14	6.9	13.2	4.6	1
FS5972-60-07	9.3	2.6	16.1	8.1	15.4	8.8	1
FS5972-100-35	3.5	5.9	13	2.6	10	7.5	2
FS5972-170-40	4.7	6.7	17.8	4	14.4	13.2	2
FS5972-250-37	5.1	9.5	24	3.5	19.6	25.8	2
FS5972-410-99	10.2	4.5	15.2	9.3	4.7	23.1	3
UFI000032	10.2	5.3	15.2	9.3	4.7	24.3	3
UFI000033	11.8	6.3	28.2	10.8	8.3	31.5	3

## EMC Filters (continued)

### 240V Class

HP	Drive Model Number CIMR-AU2A		Noise Filter by EPCOS			Noise Filter by Schaffner EMC		
	Normal Duty	Heavy Duty	Yaskawa Part Number	Qty.	Rated Current (A)	Yaskawa Part Number	Qty.	Rated Current (A)
0.5	0004	0004	UFI000177	1	8	FS5972-10-07	1	10
0.75	0004	0004	UFI000177	1	8	FS5972-10-07	1	10
1	0006	0006	UFI000177	1	8	FS5972-10-07	1	10
1.5	0006	0008	UFI000178	1	16	FS5972-10-07	1	10
2	0008	0008	UFI000178	1	16	FS5972-10-07	1	10
3	0010	0012	UFI000179	1	25	FS5972-18-07	1	18
5	0018	0021	UFI000180	1	36	FS5972-35-07	1	35
7.5	0021	0030	UFI000180	1	36	FS5972-35-07	1	35
10	0030	0040	UFI000182	1	66	FS5972-60-07	1	60
15	0040	0056	UFI000182	1	66	FS5972-60-07	1	60
20	0056	0069	UFI000183	1	90	FS5972-100-35	1	100
25	0069	0081	UFI000184	1	120	FS5972-100-35	1	100
30	0081	0110	UFI000185	1	150	FS5972-170-40	1	170
40	0110	0138	UFI000186	1	250	FS5972-170-40	1	170
50	0138	0169	UFI000186	1	250	FS5972-250-37	1	250
60	0169	0211	UFI000186	1	250	FS5972-250-37	1	250
75	0211	0250	UFI000187	1	320	FS5972-410-99	1	410
100	0250	0312	UFI000188	1	400	FS5972-410-99	1	410
125	0312	0360	UFI000189	1	600	UFI000032	1	600
150	0360	0415	UFI000189	1	600	UFI000032	1	600
175	0415	-	UFI000189	1	600	UFI000032	1	600

Note: Schaffner filters must be used when IEC/EN61508 (functional safety) conformance is required with the Safe-Torque-Off function.

### 480V Class

HP	Drive Model Number CIMR-AU4A		Noise Filter by EPCOS			Noise Filter by Schaffner EMC		
	Normal Duty	Heavy Duty	Yaskawa Part Number	Qty.	Rated Current (A)	Yaskawa Part Number	Qty.	Rated Current (A)
0.75	0002	0002	UFI000177	1	8	FS5972-10-07	1	10
2	0004	0004	UFI000178	1	16	FS5972-10-07	1	10
3	0005/0007	0005/0007	UFI000178	1	16	FS5972-10-07	1	10
5	0009	0009/0011	UFI000179	1	25	FS5972-18-07	1	18
7.5	0011	0018	UFI000180	1	36	FS5972-35-07	1	35
10	0018	0023	UFI000180	1	36	FS5972-35-07	1	35
15	0023	0031	UFI000180	1	36	FS5972-35-07	1	35
20	0031	0038	UFI000181	1	50	FS5972-60-07	1	60
25	0038	0044	UFI000182	1	66	FS5972-60-07	1	60
30	0044	0058	UFI000182	1	66	FS5972-60-07	1	60
40	0058	0072	UFI000183	1	90	FS5972-100-35	1	100
50	0072	0088	UFI000184	1	120	FS5972-100-35	1	100
60	0088	0103	UFI000185	1	150	FS5972-170-40	1	170
75	0103	0139	UFI000186	1	250	FS5972-170-40	1	170
100	0139	0165	UFI000186	1	250	FS5972-170-40	1	170
125	0165	0208	UFI000186	1	250	FS5972-250-37	1	250
150	0208	0250	UFI000188	1	400	FS5972-410-99	1	410
200	0250	0296	UFI000188	1	400	FS5972-410-99	1	410
250	0296	0362	UFI000188	1	400	FS5972-410-99	1	410
300	0362	0414	UFI000189	1	600	UFI000032	1	600
350	0414	0515	UFI000189	1	600	UFI000032	1	600
450	0515	0675	UFI000190	1	1000	UFI000033	1	800
550	0675	0930	UFI000191	1	1600	UFI000032	2	600
800	0930	1200	UFI000192	1	2500	UFI000033	2	800
1000	1200	-	UFI000192	1	2500	UFI000033	2	800

Note: Schaffner filters must be used when IEC/EN61508 (functional safety) conformance is required with the Safe-Torque-Off function.

# Power Accessories Selection

## Dynamic Braking Options

Dynamic braking provides a method to dissipate energy from regenerative events such as high inertia, fast decelerations or overhauling applications (e.g. downhill conveyors or eccentric loads). A dynamic braking system consists of a brake transistor and a brake resistor. A1000 drives through 50HP (normal duty) have built-in brake chopper transistors. A separately mounted Braking Unit (separate brake transistor) is available for larger drives.

A drive mounted 3% duty cycle resistor is available for 240V and 480V A1000 drives through 7.5HP normal duty (and 5HP heavy duty). For larger drives, higher duty cycles, and 600V applications, separately mounted resistor assemblies are available.

### Connection Diagram

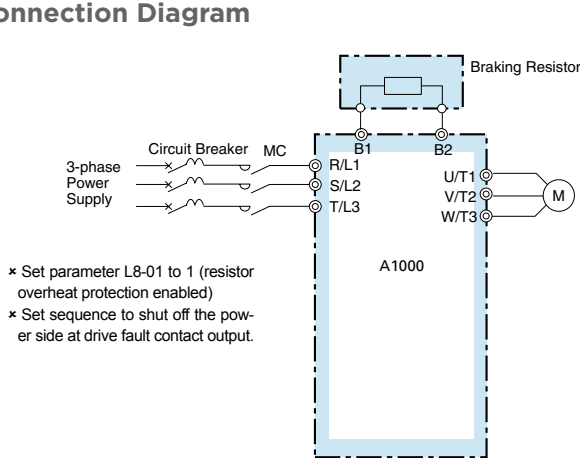

Connection Diagram A

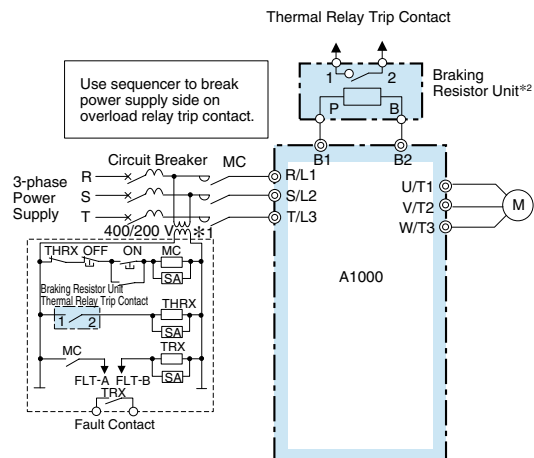

Connection Diagram B

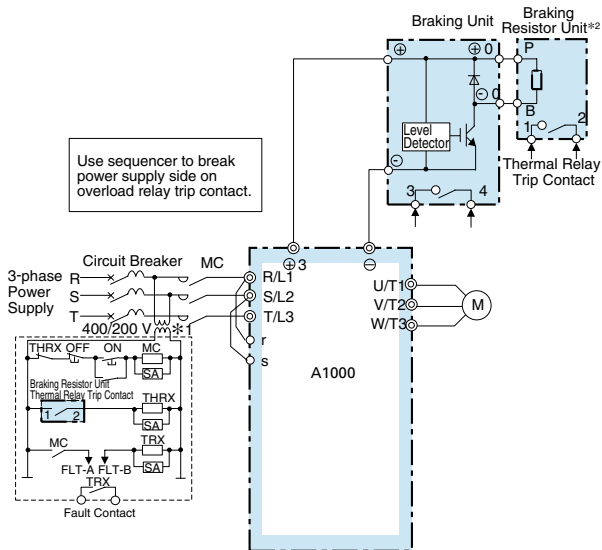

Connection Diagram C

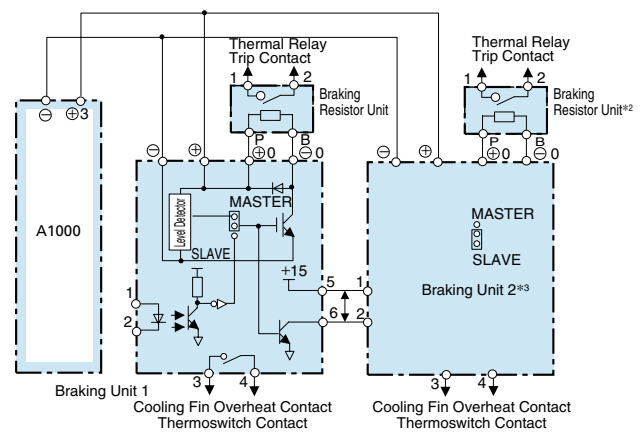

Connection Diagram D

\*1: 240V class drives do not require control circuit transformer.

\*2: Disable stall prevention during deceleration by setting L3-04 = 0 when using a Braking Resistor Unit. The motor may not stop within the deceleration time if this setting is not changed.

\*3: When using more than one parallel-connected braking unit, connect and select connectors: Braking units have a MASTER/SLAVE selection connector. Select MASTER side only for braking unit1 and select SLAVE sides for other braking units.

Note: When connecting a separately-installed type braking unit (model CDBR) to drives with built-in braking transistor (240V/480V 50HP or less), connect the B1 terminal of the drive to the positive terminal of the braking resistor unit and connect the negative terminal of the drive to the negative terminal of the braking resistor unit. The B2 terminal is not used in this case.

# Dynamic Braking Options (continued)

## Braking Unit



Braking Unit [CDBR series]

CDBR-.....	Heat Loss (W)
2015B	32
2022B	38
2110B	64
4030B	54
4045B	59
4220B	71

## Dimensions

CDBR-2015B, -2022B, -4030B, -4045B

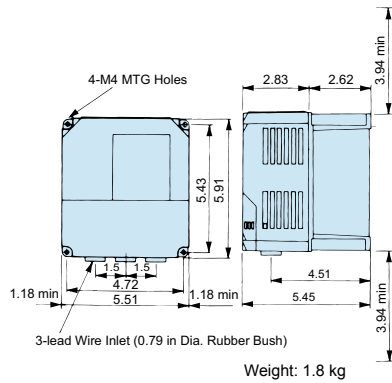

CDBR-2110B

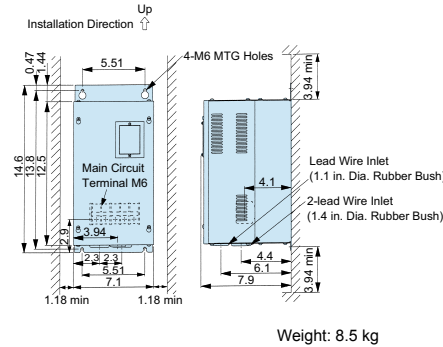

CDBR-4220B

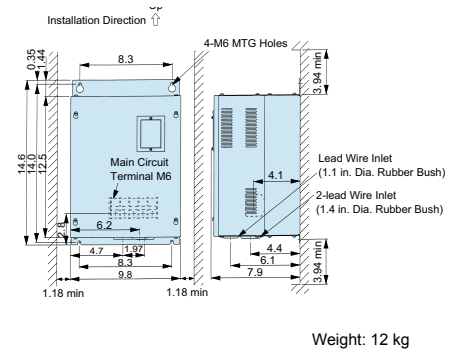

## Braking Resistor



3% Braking Resistor (R75XX)

An attachment (option) is required for installation of the braking resistor.

## Dimensions (in.)

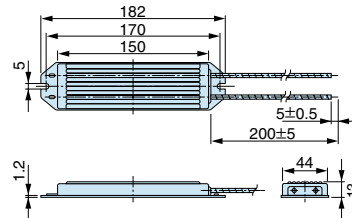

Weight: 0.2 kg (All R75XX Series models)

## Attachment for Braking Resistor

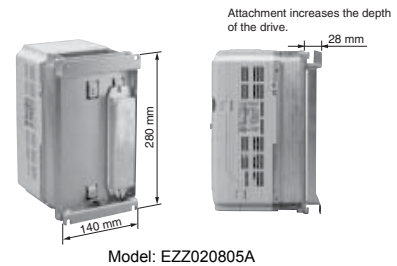

## Braking Resistor Unit (Stand-alone)



Stand-alone

## Dimensions (in.)

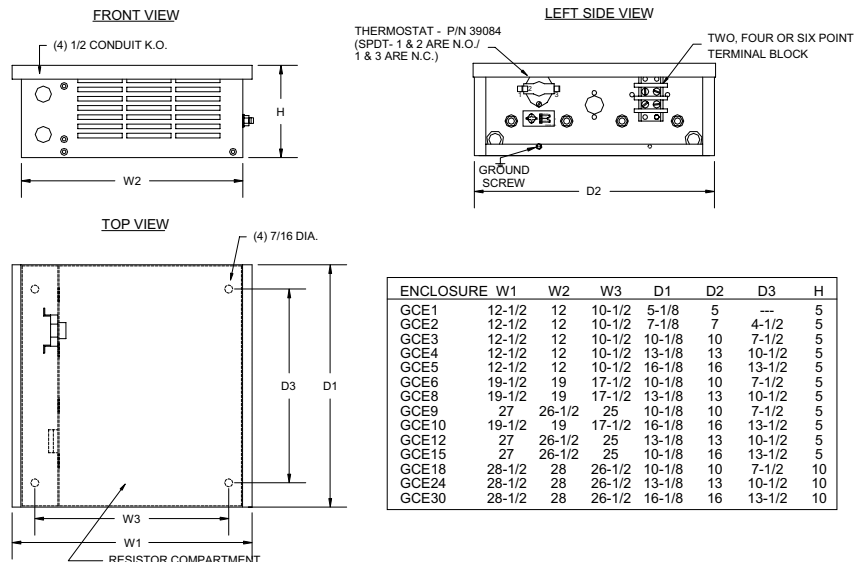

# Power Accessories Selection

## Dynamic Braking Options (continued)

240V Class

Max. Motor (HP)	ND/HD	A1000	Braking Unit		Braking Resistor (Duty Factor: 3% ED, 10 s max)					Braking Resistor Unit (Duty Factor: 10% ED, 10 s max)					Min.* Connection Resistance (Ω)											
					No Fuse																					
			Model CIMR-AU2A	Model CDBR- [ ]	Qty.	Yaskawa Part Number	Resistance (Ω)	Qty.	Diag.	Braking Torque (%)	Yaskawa Part Number	Resistor Specs (Ω)	Qty.	Diag.		Braking Torque (%)										
0.75	HD	0004	Built-in																							
	ND	0004														R7505	200	1	A	220	URS000275	170	1	B	150	48
1	HD	0006														R7505	200	1	A	125	URS000262	250	1	B	100	48
	ND	0006																		125	URS000276	125	1	B	150	48
2	HD	0008														R7504	100	1	A	125	URS000277	85	1	B	150	48
	ND	0008																		125	URS000265	95	1	B	100	48
	HD	0010																		125	URS000278	63	1	B	150	48
3	ND	0010														R7503	70	1	A	120	URS000266	63	1	B	100	48
	HD	0012																		120	URS000279	42	1	B	150	16
	ND	0012														R7510	62			100	URS000267	38	1	B	100	16
	HD	0018																		100	URS000280	25	1	B	150	16
5	ND	0018														R7510	62	1	A	80	URS000267	38	1	B	100	16
	HD	0021																		80	URS000280	25	1	B	150	
7.5	ND	0021														R7510	62	2	A	110	URS000268	26	1	B	100	16
	HD	0030														-	-			-	-	URS000280	16.8	1	B	
10	ND	0030														-	-	-	-	-	URS000269	19	1	B	100	16
	HD	0040														-	-			-	-	URS000282	12.6	1	B	
15	ND	0040														-	-	-	-	-	URS000270	12.6	1	B	100	9.6
	HD	0056														-	-			-	-	URS000283	8.4	1	B	
20	ND	0056														-	-	-	-	-	URS000271	9.6	1	B	100	9.6
	HD	0069	-	-	-	-	URS000284	6.3	1	B	150															
25	ND	0069	-	-	-	-	-	URS000272	7.5	1	B	100	9.6													
	HD	0081	-	-			-	-	URS000285	5	1	B		150												
30	ND	0081	-	-	-	-	-	URS000273	6.3	1	B	100	9.6													
	HD	0110	-	-			-	-	URS000286	4.2	1	B		150												
40	ND	0110	-	-	-	-	-	URS000274	4.9	1	B	100	6.4													
	HD	0138	-	-			-	-	URS000286	4.2	1	B		150												
50	ND	0138	-	-	-	-	-	URS000117	4.2	1	B	100	6.4													
	HD	0169	2110B	1			-	-	-	URS000100	2.1	1		C	150											
60	ND	0169	2110B	1	-	-	-	URS000100	2.1	1	C	150	1.6													
	HD	0211			-	-	-																			
75	ND	0211	2110B	1	-	-	-	URS000096	1.6	1	C	150	1.6													
	HD	0250			-	-	-																			
100	ND	0250	2110B & 2022B	1 each	-	-	-	URS000096 & URS000128	1.6 & 6.8	1 each	D	150	1.6 & 6.4													
	HD	0312			-	-	-																			
125	ND	0312	2110B & 2022B	1 & 2	-	-	-	URS000096 & URS000127	1.6 & 6.8	1 each	D	150	1.6 & 6.4													
	HD	0360			-	-	-																			
150	ND	0360	2110B	2	-	-	-	URS000097	1.6	1	D	150	1.6													
	HD	0415			-	-	-																			
175	ND	0415	2110B	2	-	-	-	URS000097	1.6	1	D	150	1.6													

\* The value shown for the minimum connection resistance is that for a single braking unit. Select a resistance value higher than the connectable resistance value and enough to generate the required braking torque.

Note: 1. The rated output current of the drive output amps should be equal to or greater than the motor rated current.  
2. An attachment (option) is required for installation of the braking resistor (Part Number R75XX). Contact Yaskawa for details.

# Dynamic Braking Options (continued)

480V Class

Max. Motor (HP)	ND/HD	A1000 Model CIMR-AU4A	Braking Unit		Braking Resistor (Duty Factor: 3% ED, 10 s max)						Braking Resistor Unit (Duty Factor: 10% ED, 10 s max)					Min.* Connection Resistance (Ω)
					No Fuse											
					Yaskawa Part Number	Resistance (Ω)	Qty.	Diag.	Braking Torque (%)	Yaskawa Part Number	Resistor Specs (Ω)	Qty.	Diag.	Braking Torque (%)		
0.75	HD	0002	Built-in	-	R7508	750	1	A	230	URS000252	500	1	B	150	96	
	ND	0002			-	-	-	-	130	URS000240	750	1	B	100	96	
2	HD	0004		R7508	750	1	A	130	URS000253	250	1	B	150	96		
	ND	0004		R7508	750			URS000241	375	1	B	100	96			
3	HD	0005		R7507	400	1	A	125	URS000254	170	1	B	150	64		
	ND	0005		-	-			115	URS000242	250	1	B	100	64		
	HD	0007		R7506	300			100	URS000243	150	1	B	100	64		
	ND	0007		R7505	200			100	URS000255	100	1	B	150	32		
5	HD	0009		R7505	200	1	A	83	URS000243	150	1	B	100	32		
	ND	0009		-	-			URS000255	100	1	B	150	32			
	HD	0011		-	-			-	-	-	-	-	-	-	-	
7.5	ND	0011		R7505	200	2	A	135	URS000244	100	1	B	100	32		
	HD	0018		-	-	-	-	-	URS000256	67	1	B	150	32		
10	ND	0018		-	-	-	-	-	URS000245	75	1	B	100	32		
	HD	0023		-	-	-	-	-	URS000257	50	1	B	150	32		
15	ND	0023		-	-	-	-	-	URS000246	50	1	B	100	32		
	HD	0031		-	-	-	-	-	URS000258	34	1	B	150	20		
20	ND	0031		-	-	-	-	-	URS000247	38	1	B	100	20		
	HD	0038		-	-	-	-	-	URS000259	25	1	B	150	20		
25	ND	0038		-	-	-	-	-	URS000248	30	1	B	100	20		
	HD	0044		-	-	-	-	-	URS000259	25	1	B	150	19.2		
30	ND	0044		-	-	-	-	-	URS000249	25	1	B	100	19.2		
	HD	0058		-	-	-	-	-	URS000260	17	1	B	150	19.2		
40	ND	0058		-	-	-	-	-	URS000250	19	1	B	100	19.2		
	HD	0072		-	-	-	-	-	URS000261	12.6	1	B	150	19.2		
50	ND	0072		-	-	-	-	-	URS000251	15	1	B	100	19.2		
	HD	0088		4045B	2	-	-	-	URS000151	18	1	D	150	12.8		
60	ND	0088		4045B	1	-	-	-	URS000144	13.6	1	D	150	12.8		
	HD	0103		4045B	2	-	-	-	URS000151	18						
75	ND	0103		4045B	2	-	-	-	URS000143	13.6	1	D	150	12.8		
	HD	0139	-	-	-	-	-	-	-	-	-	-	-			
100	ND	0139	4220B	1	-	-	-	URS000119	4.2	1	D	150	3.2			
	HD	0165	-	-	-	-	-	-	-	-	-	-	-			
125	ND	0165	4220B	1	-	-	-	URS000119	4.2	1	D	150	3.2			
	HD	0208	-	-	-	-	-	-	-	-	-	-	-			
150	ND	0208	4220B	1	-	-	-	URS000165	3.2	1	D	150	3.2			
	HD	0250	-	-	-	-	-	-	-	-	-	-	-			
200	ND	0250	4220B & 4045B	1 Each	-	-	-	URS000165 & URS000142	3.2 & 13.6	1 each	D	150	3.2 & 12.8			
	HD	0296	-	-	-	-	-	-	-	-	-	-	-			
250	ND	0296	4220B & 4045B	1 & 2	-	-	-	URS000165 & URS000143	3.2 & 13.6	1 each	D	150	3.2 & 12.8			
	HD	0362	-	-	-	-	-	-	-	-	-	-	-			
300	ND	0362	4220B	2	-	-	-	URS000166	3.2	1	D	150	3.2			
	HD	0414	-	-	-	-	-	-	-	-	-	-	-			
350	ND	0414	4220B	2	-	-	-	URS000166	3.2	1	D	150	3.2			
	HD	0515	-	-	-	-	-	-	-	-	-	-	-			
400	ND	0515	4220B	3	-	-	-	URS000167	3.2	1	D	150	3.2			
	HD	0675	-	-	-	-	-	-	-	-	-	-	-			
450	ND	0515	4220B	3	-	-	-	URS000167	3.2	1	D	150	3.2			
	HD	0675	-	-	-	-	-	-	-	-	-	-	-			
500	ND	0675	4220B	3	-	-	-	URS000167	3.2	1	D	150	3.2			
	HD	0675	-	-	-	-	-	-	-	-	-	-	-			
550	ND	0675	4220B	4	-	-	-	URS000166	3.2	2	D	150	3.2			
	HD	0930	-	-	-	-	-	-	-	-	-	-	-			
600	ND	0930	4220B	4	-	-	-	URS000166	3.2	2	D	150	3.2			
	HD	0930	-	-	-	-	-	-	-	-	-	-	-			
700	ND	0930	4220B	4	-	-	-	URS000166	3.2	2	D	150	3.2			
	HD	1200	-	-	-	-	-	-	-	-	-	-	-			
750	ND	0930	4220B	5	-	-	-	URS000166 & URS000167	3.2 each	1 each	D	150	3.2			
	HD	1200	-	-	-	-	-	-	-	-	-	-	-			
800	ND	1200	4220B	6	-	-	-	-	URS000167	3.2	2	D	150	3.2		
	HD	1200			-	-	-	-								
900	ND	1200			-	-	-	-							-	
	HD	1200			-	-	-	-							-	
1000	ND	1200			-	-	-	-							-	
	HD	1200			-	-	-	-							-	

\* The value shown for the minimum connection resistance is that for a single braking unit. Select a resistance value higher than the connectable resistance value and enough to generate the required braking torque.

Note: 1. The rated output current of the drive output amps should be equal to or greater than the motor rated current.  
2. An attachment (option) is required for installation of the braking resistor (Part Number R75XX). Contact Yaskawa for details.

# Power Accessories Selection

## Dynamic Braking Options (continued)

600V Class

Max. Motor (HP)	ND/HD	A1000 Model CIMR-AU5A	Braking Unit		Braking Resistor (Duty Factor: 3% ED, 10 s max)					Braking Resistor Unit (Duty Factor: 10% ED, 10 s max)					Min.* Connection Resistance (Ω)
					No Fuse										
					Yaskawa Part Number	Resistance (Ω)	Qty.	Diag.	Braking Torque (%)	Yaskawa Part Number	Resistor Specs (Ω)	Qty.	Diag.	Braking Torque (%)	
1	HD	0003	Built-in		-	-	-	-	-	URS000229	400	1	B	150	150
	ND	0003			-	-	-	-	-	URS000219	575	1	B	100	150
2	HD	0004		-	-	-	-	-	URS000229	400	1	B	150	150	
	ND	0003		-	-	-	-	-	URS000219	575	1	B	100	150	
3	HD	0006		-	-	-	-	-	URS000230	260	1	B	150	150	
	ND	0004		-	-	-	-	-	URS000220	400	1	B	100	150	
5	ND	0006		-	-	-	-	-	URS000221	235	1	B	100	150	
	HD	0009		-	-	-	-	-	URS000231	160	1	B	150	130	
7.5	ND	0009		-	-	-	-	-	URS000222	150	1	B	100	130	
	HD	0011		-	-	-	-	-	URS000232	100	1	B	150	90	
10	ND	0011		-	-	-	-	-	URS000223	120	1	B	100	90	
	HD	0017		-	-	-	-	-	URS000233	80	1	B	150	65	
15	ND	0017		-	-	-	-	-	URS000224	78	1	B	100	65	
	HD	0022		-	-	-	-	-	URS000234	52	1	B	150	44	
20	ND	0022		-	-	-	-	-	URS000225	59	1	B	100	44	
	HD	0027		-	-	-	-	-	URS000235	39	1	B	150	32	
25	ND	0027		-	-	-	-	-	URS000226	47	1	B	100	32	
	HD	0032		-	-	-	-	-	URS000239	32	1	B	150	29	
30	ND	0032		-	-	-	-	-	URS000227	39	1	B	100	29	
	HD	0041		-	-	-	-	-	URS000236	26	1	B	150	15	
40	ND	0041		-	-	-	-	-	URS000157	21.25**	1	B	100	15	
	HD	0052		-	-	-	-	150					15		
50	ND	0052		-	-	-	-	-	URS000226	47	1	B	100	15	
	HD	0062		5037B	2	-	-	-	-	URS000155	27.2	1	D	150	23.8
60	ND	0062		5037B	2	-	-	-	-	URS000155	27.2	1	D	150	23.8
	HD	0077		-	-	-	-	-							
75	ND	0077		5110B	1	-	-	-	-	URS000138	10.5	1	C	150	9.5
	HD	0099		-	-	-	-	-							
100	ND	0099		5300B	1	-	-	-	-	URS000118	4.2	1	C	150	3.8
	HD	0125		-	-	-	-	-							
125	ND	0125	5300B	1	-	-	-	-	URS000163	3.2	1	C	150	3.8	
	HD	0145	-	-	-	-	-								
150	ND	0145	5300B	1	-	-	-	-	URS000125	5.2	1	C	150	3.8	
	HD	0192	-	-	-	-	-								
200	ND	0192	5300B	1	-	-	-	-	URS000122	4.2	1	C	150	3.8	
	HD	0242	-	-	-	-	-								
250	ND	0242	5300B	2	-	-	-	-	URS000163	3.2	2	D	150	3.8	
	HD	0242	-	-	-	-	-								

\* The value shown for the minimum connection resistance is that for a single braking unit. Select a resistance value higher than the connectable resistance value and enough to generate the required braking torque.

Note: 1. The rated output current of the drive output amps should be equal to or greater than the motor rated current.  
2. An attachment (option) is required for installation of the braking resistor (Part Number R75XX). Contact Yaskawa for details.

\*\* Make the connection on URS000157 to parallel the resistors to change resistance from 42.5 ohms to 21.25 ohms



# Mechanical Installation Planning

## Cabinet Mounting Choices

The protected chassis type drive can be installed either completely inside of a cabinet, or with its heatsink external, thus reducing the amount of heat inside the cabinet and allowing for a more compact enclosure. Be sure to leave enough clearance during installation for ventilation and proper cooling as well as access to wiring for maintenance.

### External Heatsink Mounting

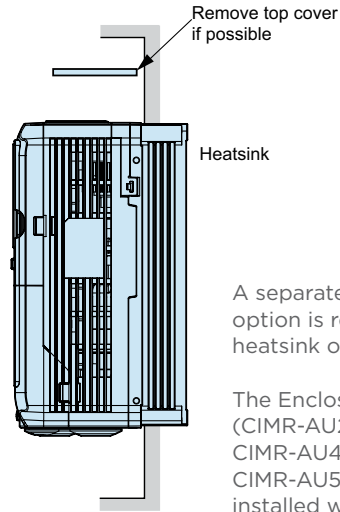
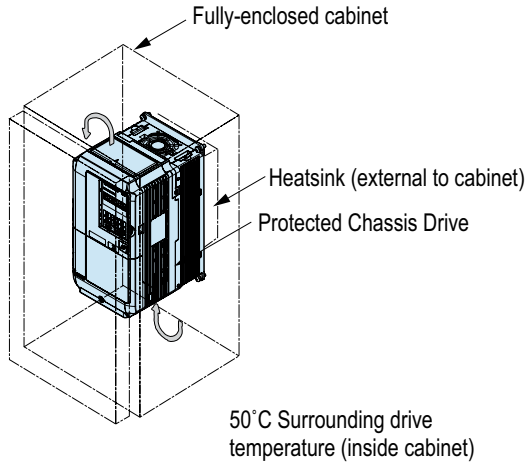

A separate mounting bracket option is required to install the heatsink outside the enclosure.

The Enclosure Panel type models (CIMR-AU2A0004 to 0081, CIMR-AU4A0002 to 0044, and CIMR-AU5A003 to 0032) can be installed with the top and bottom covers removed.

### Ventilation Space

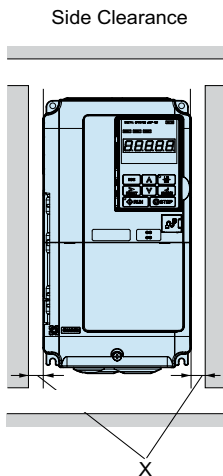

Surrounding Drive Temperature	40°C	50°C
	Side Clearance (X)	0.0 in.

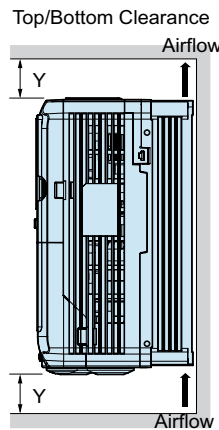

Top/Bottom Clearance (Y)	4.72 in.
--------------------------	----------

For installing the drive with capacity of AU2A0110 / AU4A0058 / AU5A0041 or greater, be sure to leave enough clearance during installation for suspension eye bolts on both sides of the unit and main circuit wiring for maintenance.

# Mechanical Installation Planning

## Drive Dimensions

### NEMA Type 1 [IP20] Diagram

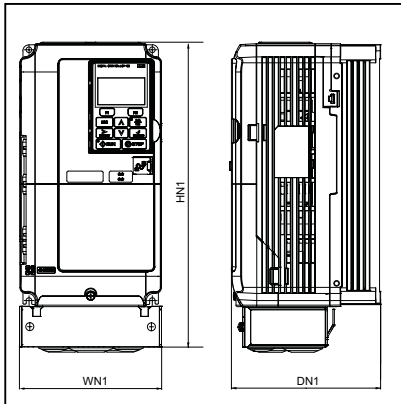

A1000 with NEMA Type 1 Kit Installed

### Protected Chassis/External Heatsink Diagram

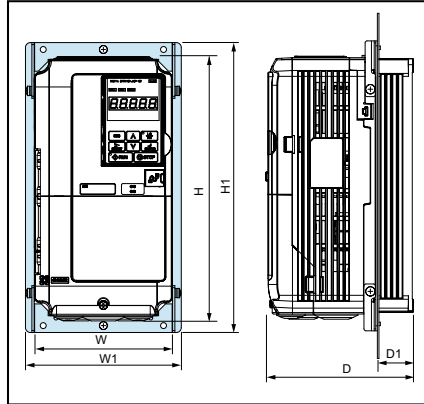

A1000 Protected Chassis / External Heatsink Configuration

#### Notes:

1. The diagrams shown are simplified dimensional diagrams designed to display key outer dimensions of the drive. They are meant for planning purposes only. For more detailed dimensional/mounting data, please refer to the A1000 dimensional drawings on [www.yaskawa.com](http://www.yaskawa.com)
2. Drives with NEMA Type 1 Enclosures can be converted to protected chassis by removing the top and bottom covers.
3. When mounting standard drives with heatsink external (NEMA 1 backside), the following models require a separately sold bracket kit: CIMR-AU2A0004Fxx to 0081Fxx, CIMR-AU4A0002Fxx to 0044Fxx, and CIMR-AU5A0003Fxx to 0032Fxx. Larger standard drives include brackets that must be detached from the back and reattached at the midpoint.
4. When NEMA 12 backside integrity is required, the Flange version drives (ending with Uxx) must be ordered.

### 240V Class

Model CIMR-AU2A □□□□	Frame Size	Max. Applicable Motor Capacity (HP)	Dimensions (in.)									Weight (lb)	
			WN1	W	W1	HN1	H	H1	DN1	D	D1	NEMA 1	Protected Chassis
0004	1	0.75	5.51	5.51	7.64	12.06	10.24	11.81	5.79	5.79	1.34	7.3	--
0006		1.5	5.51	5.51	7.64	12.06	10.24	11.81	5.79	5.79	1.34	7.3	--
0008		2	5.51	5.51	7.64	12.06	10.24	11.81	5.79	5.79	1.34	7.5	--
0010		3	5.51	5.51	7.64	12.06	10.24	11.81	5.79	5.79	1.34	7.5	--
0012		3	5.51	5.51	7.64	12.06	10.24	11.81	5.79	5.79	1.34	7.5	--
0018	2	5	5.51	5.51	7.64	12.06	10.24	11.81	6.46	6.46	2.06	8.2	--
0021		7.5	5.51	5.51	7.64	12.06	10.24	11.81	6.46	6.46	2.06	8.2	--
0030	3	10	5.51	5.51	7.64	12.06	10.24	11.81	6.57	6.57	2.07	9.3	--
0040		15	5.51	5.51	7.64	12.06	10.24	11.81	6.57	6.57	2.07	9.3	--
0056	5	20	7.09	7.09	9.21	13.38	11.81	13.39	7.36	7.36	2.83	13.0	--
0069	6	25	8.66	8.66	11.65	15.47	13.78	16.54	7.76	7.76	2.91	20.1	--
0081		30	8.66	8.66	11.65	15.47	13.78	16.54	7.76	7.76	2.91	22.0	--
0110	7A	40	10.00	10.00	12.13	21.37	15.75	16.3	10.16	10.16	3.82	50.7	46.2
0138	8A	50	10.98	10.98	12.99	24.52	17.72	18.11	10.16	10.16	3.81	61.7	55.0
0169	10	60	12.95	12.95	15.2	30.08	21.65	22.13	11.14	11.14	4.21	90.2	81.4
0211		75	12.95	12.95	15.2	30.08	21.65	22.13	11.14	11.14	4.21	92.4	83.6
0250	11	100	17.95	17.72	22.05	37.80	27.76	28.54	12.99	12.99	5	191.8	167.6
0312		125	17.95	17.72	22.05	37.80	27.76	28.54	12.99	12.99	5	191.8	176.4
0360	12	150	19.84	19.69	23.62	45.98	31.50	32.28	13.78	13.78	5	233.7	216.1
0415		175	19.84	19.69	23.62	45.98	31.50	32.28	13.78	13.78	5	233.7	218.3

## 480V Class

Model CIMR-AU4A □□□□	Frame Size	Max. Applicable Motor Capacity (HP)	Dimensions (in.)									Weight (lb)	
			WN1	W	W1	HN1	H	H1	DN1	D	D1	NEMA 1	Protected Chassis
0002	1	1	5.51	5.51	7.64	12.06	10.24	11.81	5.79	5.79	1.34	7.3	--
0004		2	5.51	5.51	7.64	12.06	10.24	11.81	5.79	5.79	1.34	7.3	--
0005		3	5.51	5.51	7.64	12.06	10.24	11.81	5.79	5.79	1.34	7.3	--
0007	2	3	5.51	5.51	7.64	12.06	10.24	11.81	6.46	6.46	2.06	8.2	--
0009		5	5.51	5.51	7.64	12.06	10.24	11.81	6.46	6.46	2.06	8.2	--
0011		7.5	5.51	5.51	7.64	12.06	10.24	11.81	6.46	6.46	2.06	8.2	--
0018	3	10	5.51	5.51	7.64	12.06	10.24	11.81	6.57	6.57	2.07	9.3	--
0023		15	5.51	5.51	7.64	12.06	10.24	11.81	6.57	6.57	2.07	9.3	--
0031	4	20	7.09	7.09	9.21	13.38	11.81	13.39	6.88	6.88	2.04	12.5	--
0038	5	25	7.09	7.09	9.21	13.38	11.81	13.39	7.36	7.36	2.83	13.0	--
0044	6	30	8.66	8.66	11.65	15.47	13.78	16.54	7.76	7.76	2.91	20.1	--
0058	7B	40	10.37	10.37	12.13	18.65	15.75	16.3	10.16	10.16	3.82	50.6	50.6
0072	8B	50	11.35	11.35	12.99	20.62	17.72	18.11	10.16	10.16	3.81	59.4	59.4
0088	9	60	13.32	13.16	15.35	25.16	20.06	21.34	10.27	10.27	3.97	85.8	79.2
0103		75	13.32	13.16	15.35	25.16	20.06	21.34	10.27	10.27	3.97	85.8	79.2
0139	10	100	12.95	12.95	15.2	30.08	21.65	22.13	11.14	11.14	4.21	99.0	90.2
0165		125	12.95	12.95	15.2	30.08	21.65	22.13	11.14	11.14	4.21	101	92.4
0208	11	150	17.95	17.72	22.05	37.80	27.76	28.54	12.99	12.99	5	191	174
0250	12	200	19.84	19.69	23.62	45.98	31.50	32.28	13.78	13.78	5	233	211
0296		250	19.84	19.69	23.62	45.98	31.50	32.28	13.78	13.78	5	246	224
0362		300	19.84	19.69	23.62	45.98	31.50	32.28	13.78	13.78	5	257	235
0414	13	350	20.29	20.29	25.39	48.3	37.4	40.55	14.68	14.68	5.19	292	275
0515	14	450	26.86	26.86	31.97	61.3	44.88	46.38	14.72	14.72	7.71	504	475
0675		600	26.86	26.86	31.97	61.3	44.88	46.38	14.72	14.72	7.71	515	486
0930	15	800	50.2	49.61	--	80.4	54.33	--	14.73	14.91	--	1394	1195
1200		1000	50.2	49.61	--	80.4	54.33	--	14.73	14.91	--	1420	1221

## 600V Class

Model CIMR-AU5A □□□□□□	Frame Size	Max. Applicable Motor Capacity (HP)	Dimensions (in.)									Weight (lb)	
			WN1	W	W1	HN1	H	H1	DN1	D	D1	NEMA 1	Protected Chassis
0003	1	2	5.51	5.51	7.64	12.06	10.24	11.81	5.79	5.79	1.34	7.3	--
0004		3	5.51	5.51	7.64	12.06	10.24	11.81	5.79	5.79	1.34	7.3	--
0006	2	5	5.51	5.51	7.64	12.06	10.24	11.81	6.46	6.46	2.06	8.2	--
0009		7.5	5.51	5.51	7.64	12.06	10.24	11.81	6.46	6.46	2.06	8.2	--
0011	3	10	5.51	5.51	7.64	12.06	10.24	11.81	6.57	6.57	2.07	9.3	--
0017	5	15	7.09	7.09	9.21	13.38	11.81	13.39	7.36	7.36	2.83	13.0	--
0022		20	7.09	7.09	9.21	13.38	11.81	13.39	7.36	7.36	2.83	13.0	--
0027	6	25	8.66	8.66	11.65	15.47	13.78	16.54	7.76	7.76	2.91	20.1	--
0032		30	8.66	8.66	11.65	15.47	13.78	16.54	7.76	7.76	2.91	20.1	--
0041	8B	40	11.35	11.35	12.99	20.62	17.72	18.11	10.16	10.16	3.81	59.4	59.4
0052		50	11.35	11.35	12.99	20.62	17.72	18.11	10.16	10.16	3.81	59.4	59.4
0062	10	60	12.95	12.95	15.2	30.08	21.65	22.13	11.14	11.14	4.21	99.0	90.2
0077		75	12.95	12.95	15.2	30.08	21.65	22.13	11.14	11.14	4.21	99.0	90.2
0099		100	12.95	12.95	15.2	30.08	21.65	22.13	11.14	11.14	4.21	99.0	90.2
0125	11	125	17.95	17.72	22.05	37.80	27.76	28.54	12.99	12.99	5	191	174
0145		150	17.95	17.72	22.05	37.80	27.76	28.54	12.99	12.99	5	191	174
0192	12	200	19.84	19.69	23.62	45.98	31.50	32.28	13.78	13.78	5	233	235
0242		250	19.84	19.69	23.62	45.98	31.50	32.28	13.78	13.78	5	257	235

# Mechanical Installation Planning

## Drive Watts Loss Data

### 240V Class

Model CIMR-AU2A	Rated Amps (A) <sup>*1</sup>	Heatsink Loss (W)	Interior Unit Loss (W)	Total Loss (W)
0004	3.5	18.4	47	66
0006	6.0	31	51	82
0008	8.0	43	52	95
0010	9.6	57	58	115
0012	12.0	77	64	141
0018	17.5	101	67	168
0021	21	138	83	222
0030	30	262	117	379
0040	40	293	145	437
0056	56	371	175	546
0069	69	491	205	696
0081	81	527	257	785
0110	110	719	286	1005
0138	138	842	312	1154
0169	169	1014	380	1394
0211	211	1218	473	1691
0250	250	1764	594	2358
0312	312	2020	665	2686
0360	360	2698	894	3591
0415	415	2672	954	3626

\*1: Value assumes the carrier frequency is at default setting (refer to Technical Manual).

### 480V Class

Model CIMR-AU4A	Rated Amps (A) <sup>*1</sup>	Heatsink Loss (W)	Interior Unit Loss (W)	Total Loss (W)
0002	2.1	20	48	68
0004	4.1	32	49	81
0005	5.4	45	53	97
0007	6.9	62	59	121
0009	8.8	66	60	126
0011	11.1	89	73	162
0018	17.5	177	108	285
0023	23	216	138	354
0031	31	295	161	455
0038	38	340	182	521
0044	44	390	209	599
0058	58	471	215	686
0072	72	605	265	870
0088	88	684	308	993
0103	103	848	357	1205
0139	139	1215	534	1749
0165	165	1557	668	2224
0208	208	1800	607	2408
0250	250	2379	803	3182
0296	296	2448	905	3353
0362	362	3168	1130	4298
0414	414	3443	1295	4738
0515	515	4850	1668	6518
0675	675	4861	2037	6898
0930	930	8476	2952	11428
1200	1200	8572	3612	12184

\*1: Value assumes the carrier frequency is at default setting (refer to Technical Manual).

## Drive Watts Loss Data (continued)

600V Class

Model CIMR-AU5A[.....]	Normal Duty				Heavy Duty			
	Rated Amps (A) <sup>*1</sup>	Heatsink Loss (W)	Interior Unit Loss (W)	Total Loss (W)	Rated Amps (A) <sup>*2</sup>	Heatsink Loss (W)	Interior Unit Loss (W)	Total Loss (W)
0003	2.7	21.5	23.3	44.8	1.7	28.9	19.8	48.7
0004	3.9	27.5	33.6	61.1	3.5	54.3	27.6	81.9
0006	6.1	28.1	43.7	71.8	4.1	53.0	27.0	80.0
0009	9.0	43.4	68.9	112.3	6.3	78.7	36.4	115.1
0011	11	56.1	88.0	144.0	9.8	110.9	49.5	160.3
0017	17	96.6	146.7	243.2	12.5	144.7	67.5	212.2
0022	22	99.4	178.3	277.7	17	203.8	81.1	284.8
0027	27	132.1	227.2	359.3	22	267.2	113.8	381.1
0032	32	141.6	279.9	421.5	27	332.9	132.2	465.1
0041	41	330.8	136.2	467.0	32	405.9	127.6	533.5
0052	52	427.8	166.2	594.0	41	527.2	161.4	688.5
0062	62	791.2	279.0	1070.2	52	1271.5	335.0	1606.5
0077	77	959.1	329.4	1288.6	62	1457.0	379.5	1836.5
0099	99	1253.2	411.7	1664.9	77	1267.0	352.0	1619.0

\*1: Value assumes the carrier frequency is set to 2 kHz.

\*2: Value assumes the carrier frequency is set to 8 kHz.

# Electrical Installation Planning

## Connection Diagram

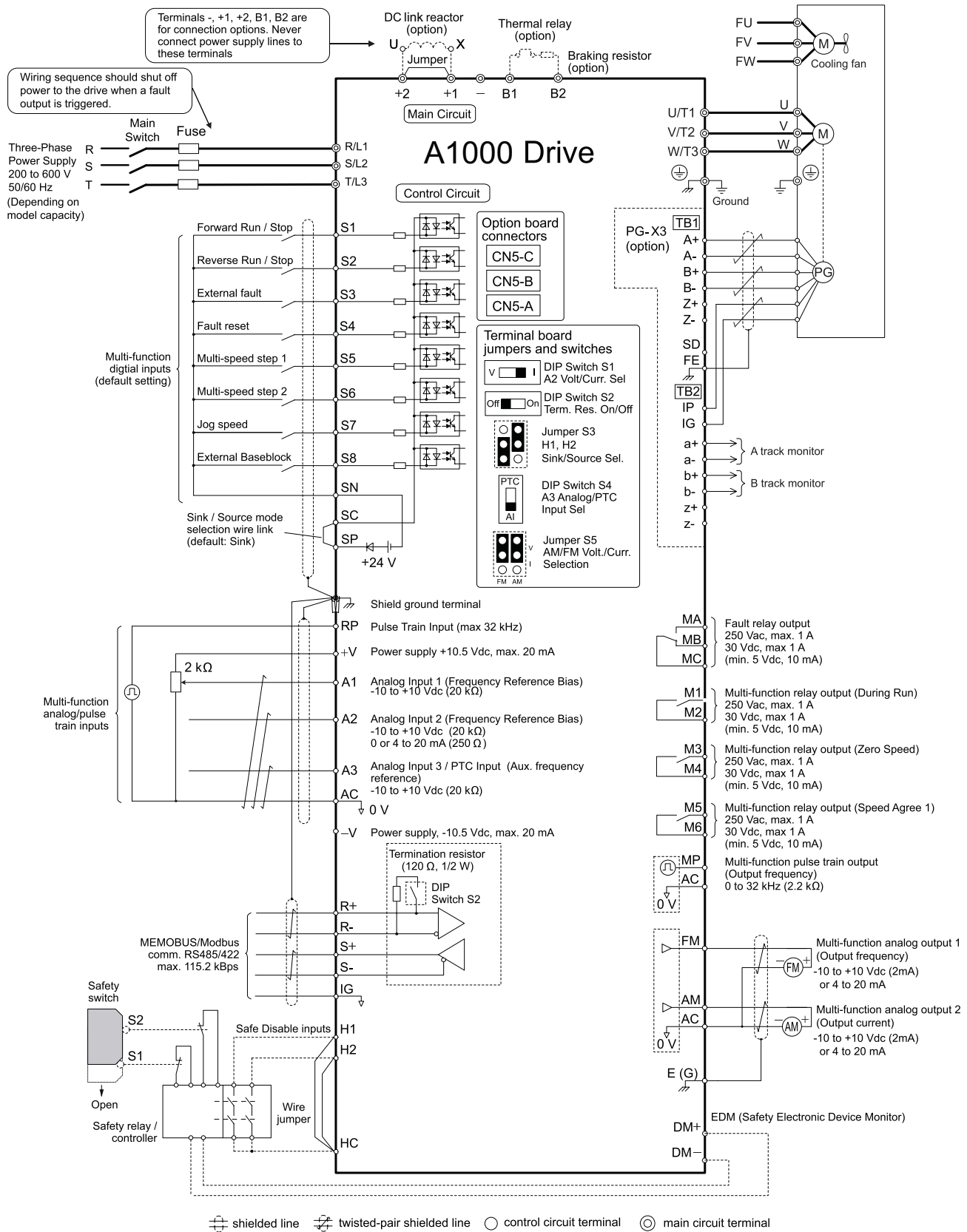

# Control Circuit and Terminal Layout

Control circuit terminals should be arranged as shown below

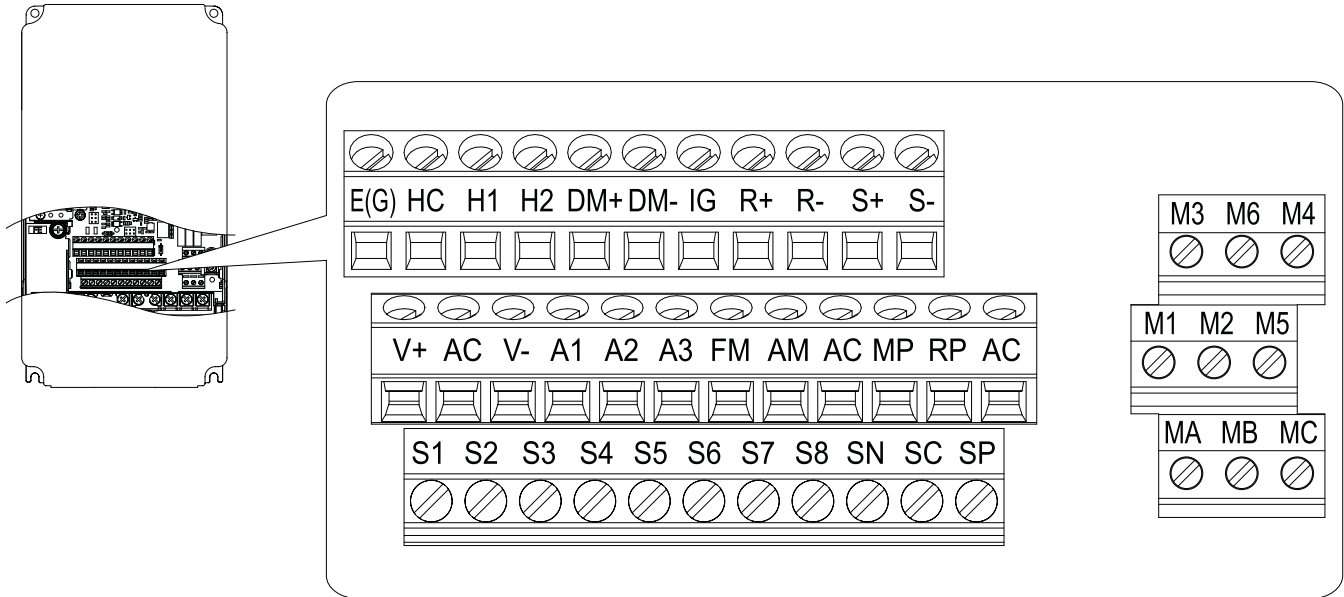

# Electrical Installation Planning

## Power Terminal Functions

### 240V Class

Voltage	240V			Function
Model CIMR-AU: [ ]	2A0004 to 2A0081	2A0110, 2A0138	2A0169 to 2A0415	
Max. Applicable Motor Capacity HP	0.75 to 30	40, 50	60 to 175	
R/L1	Main circuit input power supply			Connects line power to the drive
S/L2				
T/L3				
U/T1	Drive output			Connects to the motor
V/T2				
W/T3				
B1	Braking resistor unit		Not available	Available for connecting a braking resistor or a braking resistor unit option
B2				
+2	• DC reactor connection (+1, +2) (remove the shorting bar between +1 and +2)	Not available		For connection • of the drive to a DC power supply (terminals +1 and – are not EU/CE or UL approved) • of dynamic braking options • of a DC link reactor
+1		• DC power supply input (+1, –)	• DC power supply input (+1, –)	
–	• DC power supply input (+1, –)			
+3	Not available		• Braking unit connection (+3, –)	
⊕	Ground terminal (100 Ω or less)			Grounding terminal

### 480V Class

Voltage	480V			Function
Model CIMR-AU: [ ]	4A0002 to 4A0044	4A0058, 4A0072	4A0088 to 4A1200	
Max. Applicable Motor Capacity HP	0.75 to 30	40,50	60 to 1000	
R/L1	Main circuit input power supply			Connects line power to the drive
S/L2				
T/L3				
U/T1	Drive output			Connects to the motor
V/T2				
W/T3				
B1	Braking resistor unit		Not available	Available for connecting a braking resistor or a braking resistor unit option
B2				
+2	• DC reactor connection (+1, +2) (remove the shorting bar between +1 and +2)	Not available		For connection • of the drive to a DC power supply (terminals +1 and – are not EU/CE or UL approved) • of dynamic braking options • of a DC link reactor
+1		• DC power supply input (+1, –)	• DC power supply input (+1, –)	
–	• DC power supply input (+1, –)			
+3	Not available		• Braking unit connection (+3, –)	
⊕	Ground terminal (100 Ω or less)			Grounding terminal

### 600V Class

Voltage	600V			Function
Model CIMR-AU: [ ]	5A0003 to 5A0032	5A0041 to 5A0099	5A0125 to 5A0242	
Max. Applicable Motor Capacity HP	1 to 30	40 to 100	125 to 250	
R/L1	Main circuit input power supply			Connects line power to the drive
S/L2				
T/L3				
U/T1	Drive output			Connects to the motor
V/T2				
W/T3				
B1	Braking resistor unit		Not available	Available for connecting a braking resistor or a braking resistor unit option
B2				
+2	• DC reactor connection (+1, +2) (remove the shorting bar between +1 and +2)	Not available		For connection • of the drive to a DC power supply (terminals +1 and – are not EU/CE or UL approved) • of dynamic braking options • of a DC link reactor
+1		• DC power supply input (+1, –)	• DC power supply input (+1, –)	
–	• DC power supply input (+1, –)			
+3	Not available		• Braking unit connection (+3, –)	
⊕	Ground terminal (100 Ω or less)			Grounding terminal



# Control Terminal Functions

## Input Terminals

Classification	Terminal	Terminal Name (Function)	Default Setting	Function (Signal Level)
Multi-function Digital Inputs	S1	Multi-function input selection 1	Closed: Forward run (Open: Stop)	<ul style="list-style-type: none"> <li>• Photocoupler</li> <li>• 24 Vdc, 8 mA</li> <li>• Set the S3 jumper to select between sinking, sourcing mode, and the power supply.</li> </ul>
	S2	Multi-function input selection 2	Closed: Reverse run (Open: Stop)	
	S3	Multi-function input selection 3	External fault, N.O.	
	S4	Multi-function input selection 4	Fault reset	
	S5	Multi-function input selection 5	Multi-step speed reference 1	
	S6	Multi-function input selection 6	Multi-step speed reference 2	
	S7	Multi-function input selection 7	Jog reference	
	S8	Multi-function input selection 8	Closed: External baseblock	
	SC	Multi-function input common	Multi-function input common	
	SP	Digital input power supply +24 Vdc	24 Vdc power supply for digital inputs, 150 mA max (only when not using digital input option DI-A3)	
SN	Digital input power supply 0 V	NOTICE: Do not jumper or short terminals SP and SN. Failure to comply will damage the drive		
Safe Disable Inputs	H1	Safe Disable input 1 <sup>2</sup>	Frequency reference	<ul style="list-style-type: none"> <li>• 24 Vdc, 8 mA</li> <li>• One or both open: Output disabled</li> <li>• Both closed: Normal operation</li> <li>• Internal impedance: 3.3 kΩ</li> <li>• Off time of at least 1 ms</li> <li>• Disconnect the wire jumpers shorting terminals H1, H2, and HC to use the Safe Disable inputs. Set the S5 jumper to select between sinking, sourcing mode, and the power supply</li> </ul>
	H2	Safe Disable input 2 <sup>2</sup>		
	HC	Safe Disable input common		
Multi-function Analog/Pulse Train Inputs	RP	Multi-function pulse train input	Frequency reference	<ul style="list-style-type: none"> <li>• Input frequency range: 0 to 32 kHz</li> <li>• Signal Duty Cycle: 30 to 70%</li> <li>• High level: 3.5 to 13.2 Vdc, low level: 0.0 to 0.8 Vdc</li> <li>• Input impedance: 3 kΩ</li> </ul>
	+V	Power supply for analog inputs	+10.5 Vdc (max allowable current 20 mA)	
	-V	Power supply for analog inputs	-10.5 Vdc (max allowable current 20 mA)	
	A1	Multi-function analog input 1	Frequency reference	-10 to 10 Vdc, 0 to 10 Vdc (input impedance: 20 kΩ)
	A2	Multi-function analog input 2	Frequency reference	<ul style="list-style-type: none"> <li>• -10 to 10 Vdc, 0 to 10 Vdc (input impedance: 20 kΩ)</li> <li>• 4 to 20 mA, 0 to 20 mA (input impedance: 250 Ω)</li> <li>• Voltage or current input must be selected by DIP switch S1 and H3-09.</li> </ul>
	A3	Multi-function analog input 3	Auxiliary frequency reference/PTC Input	<ul style="list-style-type: none"> <li>• -10 to 10 Vdc, 0 to 10 Vdc (input impedance: 20 kΩ)</li> <li>• Use DIP switch S4 on the terminal board to select between analog and PTC input.</li> </ul>
	AC	Frequency reference common	0 V	
E(G)	Ground for shielded lines and option cards			

## Output Terminals

Classification	Terminal	Terminal Name (Function)	Default Setting	Function (Signal Level)
Fault Relay Outputs	MA	N.O	During run	30 Vdc, 10 mA to 1 A; 250 Vac, 10 mA to 1 A Minimum load: 5 Vdc, 10 mA
	MB	NC		
	MC	Fault output common		
Multi-Function Digital Output <sup>1</sup>	M1	Multi-function digital output	During run	30 Vdc, 10 mA to 1 A; 250 Vac, 10 mA to 1 A Minimum load: 5 Vdc, 10 mA
	M2	Multi-function digital output	Zero speed	
	M3	Multi-function digital output	Zero speed	
	M4	Multi-function digital output	Zero speed	
Monitor Output	M5	Multi-function digital output	Speed Agree 1	32 kHz (max)
	M6	Multi-function digital output	Speed Agree 1	
	MP	Pulse train output	Output frequency	
	FM	Analog monitor output 1	Output frequency	
Safety Monitor Output <sup>2</sup>	AM	Analog monitor output 2	Output current	-10 to +10 Vdc, or 0 to +10 Vdc
	AC	Monitor common	0 V	
	DM+	Safety monitor output	Outputs status of Safe Disable function. Closed when both Safe Disable channels are closed. Up to +48 Vdc 50 mA	
	DM-	Safety monitor output common		

## Communication Terminals

Classification	Terminal	Signal Function	Description	Function (Signal Level)
Modbus Communication <sup>3</sup>	R+	Communication input	Modbus communication: use an RS-485 or RS-422 cable to connect the A1000	RS-485/422 Modbus communication protocol 115.2 kbps (max.)
	R-			
	S+	Communication output		
	S-			
	IG	Shield ground		

\*1: Refrain from assigning functions to digital relay outputs that involve frequent switching, as doing so may shorten relay performance life. Switching life is estimated at 200,000 times (assumes 1 A, resistive load).

\*2: Terminals H1, H2, DM+, and DM- on 600V class models are designed to the functionality, but are not certified to EN61800-5-1, EN954-1/ISO13849 Cat. 3, IEC/EN61508 SIL2, Insulation coordination: class 1.

\*3: Enable the termination resistor in the last drive in a Modbus network by setting DIP switch S2 to the ON position.

# A1000 Configured Package

## Customizable Packages for any Environment

The A1000 Configured package provides an A1000 in a NEMA 1, NEMA 12, or NEMA 3R enclosure, with space for several commonly used options, such as reactors, RFI filters, circuit breakers, etc. These packages have been designed for flexibility in providing commonly requested features and options to provide a customized drive solution..



### Ratings

- 240 VAC: 1 to 150 HP
- 480 VAC: 1 to 1000 HP
- 600 VAC: 1 to 200 HP

### Service Conditions

- Ambient service temperature: -10 to 40°C (14 to 104°F)
- Ambient storage temperature: -20 to 60°C (-4 to 140°F)
- Humidity: 0 to 95%, non-condensing
- Altitude: Up to 1000 m (3300 ft); higher by derating
- Vibration: 0.33 mm (10 to 20 Hz), 0.22 G (20 to 55 Hz)

### Standards and Reliability

- UL 508A (Industrial Control Panels)
- UL, cUL listed

### Configured Options

- Feedback cards
- Input and output cards
- Network communication cards
- Input breaker
- Input disconnect
- Input fuses
- 120 VAC interface
- Line/load reactors
- Input filter
- Bus reactor (for small HP ratings)
- Dynamic braking
- Blower motor starter
- Door-mounted Hand/Off/Auto switch
- Door-mounted speed pot

# A1000 Configured Drive Selection

## Customizable Packages for any Environment



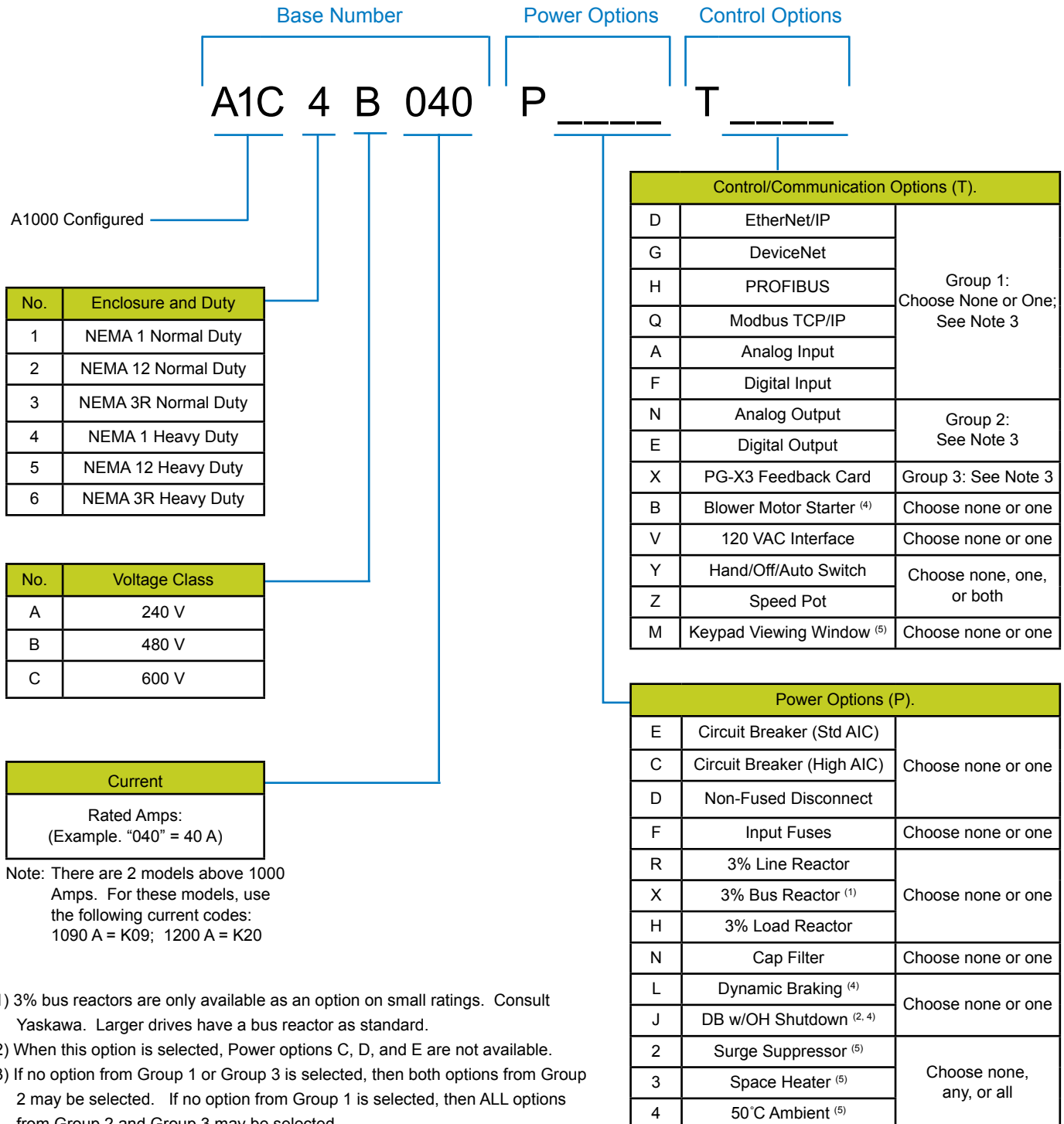









To construct a Configured model number, find the base number for the required enclosure type, voltage, and current rating. Add the option code for each required option. Power options are preceded by P and Control options are preceded by T.



- (1) 3% bus reactors are only available as an option on small ratings. Consult Yaskawa. Larger drives have a bus reactor as standard.
- (2) When this option is selected, Power options C, D, and E are not available.
- (3) If no option from Group 1 or Group 3 is selected, then both options from Group 2 may be selected. If no option from Group 1 is selected, then ALL options from Group 2 and Group 3 may be selected.
- (4) Not available for NEMA 3R enclosures
- (5) NEMA 3R enclosures only.

# Yaskawa Industrial Drives Family

## Selection Matrix

Product	Dedicated Enclosure Types	Power Range	Performance (IM = Induction Motor) (PM = Permanent Magnet Motor)		
			Volts per Hertz	Open Loop Vector	Closed Loop Vector
<b>A1000</b> General Purpose High Performance Vector	Type 1 or Protected Chassis	3/4  175HP @ 240V 3-Phase 3/4  1000HP @ 480V 3-Phase 1  250HP @ 600 VAC	40:1 (IM)	200:1 (IM) 100:1 (PM)	1500:1 (IM) 1500:1 (PM)
<b>P1000</b> Industrial Fan and Pump	Type 1 or Protected Chassis	3/4  175HP @ 240V 3-Phase 1  1000HP @ 480V 3-Phase 2  250HP @ 600 VAC	40:1 (IM)		
<b>V1000</b> Compact Vector	Type 1 Type 4X/12 or Protected Chassis	1/8  5HP @ 240V 1-Phase 1/8  25HP @ 240V 3-Phase 1/2  25HP @ 480V 3-Phase	40:1 (IM)	100:1 (IM) 10:1 (PM)	
<b>J1000</b> Ultra Compact	Protected Chassis	1/8  3HP @ 240V 1-Phase 1/8  5HP @ 240V 3-Phase 1/2  7.5HP @ 480V 3-Phase	40:1 (IM)		

Maximum Frequency	Inputs and Outputs						Communications										Auxiliary Control Power Input	Safe-Torque-Off				
	Standard (Alternate Firmware)	Analog Inputs	Analog Outputs	Digital Inputs	Digital Outputs	Pulse Train Inputs	Pulse Train Outputs	EtherNet/IP	DeviceNet	Modbus TCP/IP	Modbus RTU	MECHATROLINK-II	MECHATROLINK-III	PROFIBUS-DP	PROFINET	EtherCAT			Metasys / Apogee	BACnet	LonWorks	
400 Hz (1000 Hz)	3	2	8	4	1	1	■	■	■	●	■	■	■	■	■	■	■	■	■	■	■	Cat 3 PLd SIL CL2
120 Hz	2	2	7	3			■	■	■	●	■	■	■	■	■	■	■	■	■	■	■	
400 Hz (1167 Hz)	2	1	7	3	1	1	■	■	■	●	■	■	■	■	■	■						Cat 3
400 Hz	1	1	5	1							■											

● Standard

■ Option



# Global Service Network

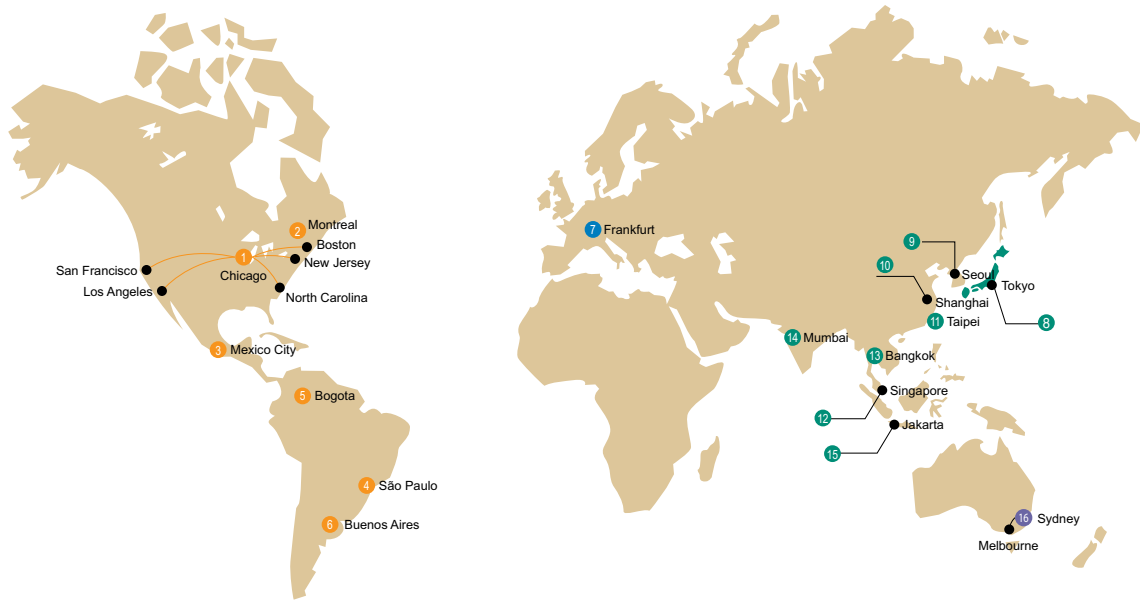

Region	Service Area	Service Location	Service Agency	Telephone/Fax
North America	U.S.A	Chicago (HQ) Los Angeles New Jersey Boston San Francisco Ohio North Carolina	① YASKAWA AMERICA, INC.	Headquarters ☎ +1-847-887-7303 FAX +1-847-887-7070
	Mexico	Mexico City	② PILLAR MEXICANA. S.A. DE C.V.	☎ +52-5593-28-69 FAX +52-5651-55-73
South America	South America	São Paulo	③ YASKAWA ELÉCTRICO DO BRASIL LTD.A.	☎ +55-11-3585-1100 FAX +55-11-5581-8795
	Colombia	Bogota	④ VARIADORES LTD.A.	☎ +57-91-635-7460 FAX +57-91-611-3872
	Argentina	Buenos Aires	⑤ ELINSUR, SRL	☎ +54-11-4918-2056 FAX +54-11-4918-1183
Europe	Europe and South Africa	Frankfurt	⑥ YASKAWA ELECTRIC EUROPE GmbH	☎ +49-6196-569-300 FAX +49-6196-569-398
			⑦ YASKAWA ENGINEERING EUROPE GmbH	☎ +49-6196-569-520 FAX +49-6196-888-598
Asia	Japan	Tokyo, offices nationwide	⑧ YASKAWA ELECTRIC CORPORATION (Manufacturing, sales)	☎ +81-3-5402-4502 FAX +81-3-5402-4580
			⑨ YASKAWA ELECTRIC ENGINEERING CORPORATION (After-sales service)	☎ +81-4-2931-1810 FAX +81-4-2931-1811
	South Korea	Seoul	⑩ YASKAWA ELECTRIC KOREA CORPORATION	☎ +82-2-784-7844 FAX +82-2-784-8495
			⑪ YASKAWA ENGINEERING KOREA Co.	☎ +82-2-3775-0337 FAX +82-2-3775-0338
			⑫ Rockwell Samsung Automation Co., Ltd.	☎ +82-331-200-2981 FAX +82-331-200-2970
	China	Beijing, Guangzhou, Shanghai	⑬ YASKAWA ELECTRIC (SHANGHAI) Co., Ltd.	☎ +86-21-5385-2200 FAX +86-21-5385-3299
	Taiwan	Taipei	⑭ YASKAWA ELECTRIC TAIWAN Co.	☎ +886-2-2502-5003 FAX +886-2-2505-1280
	Singapore	Singapore	⑮ YASKAWA ELECTRIC (SINGAPORE) Pte. Ltd.	☎ +65-6282-3003 FAX +65-6289-3003
			⑯ YASKAWA ENGINEERING ASIA-PACIFIC Pte. Ltd.	☎ +65-6282-1601 FAX +65-6282-3668
	Thailand	Bangkok	⑰ YASKAWA ELECTRIC (THAILAND) Co., Ltd.	☎ +66-2-693-2200 FAX +66-2-693-2204
India	Mumbai	⑱ LARSON & TOUBRO LIMITED	Headquarters ☎ +91-22-67226200 +91-22-27782230 FAX +91-22-27783032	
Oceania	Australia	Sydney (HQ) Melbourne	⑲ ROBOTIC AUTOMATION Pty. Ltd.	Headquarters ☎ +61-2-9748-3788 FAX +61-2-9748-3817



# YASKAWA



**Yaskawa America, Inc.**  
Drives & Motion Division

2121 Norman Drive South  
Waukegan, IL 60085  
Tel: 1-800-YASKAWA (927-5292) • Fax: 1-847-887-7310  
[www.yaskawa.com](http://www.yaskawa.com)

Document BL.A1000.01 04/15/2016 • © 2011-2016