

CURVILINE: ...the rail that goes straight to the solution!

ROLLON's CURVILINE rails represent a real "linear solution".

An economical and versatile solution for applications with non linear trajectories. The CURVILINE product is created specifically for your application in order to satisfy your specific needs. Our new flexible productive processes allow us to manufacture small quantities (100 pcs) at acceptable costs.

The system is composed of one or more sliders and a zinc-plated rail.

The slider have four high precision steel radial ball bearings designed specifically for this purpose. The rollers are lubricated for life. Strength and lifetime are guaranteed by these factors. There are two versions. The first has a constant radius and the second has variable radius. The second version can also contain straight areas.

Each version has its own slider which has been studied and designed for its specific purpose and is able to travel along the rail keeping its standard preload constant throughout the movement.

CURVILINE's applications are varied and allow us to offer "linear solutions" where none were available in the past: movements inside packaging machinery; automatic and manual door openings for machine tools, elevators, trains, busses, etc.

VARIABLE RADIUS VERSION

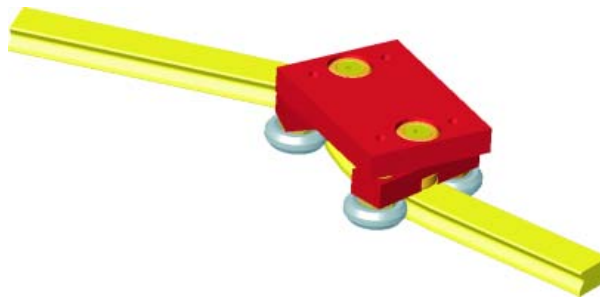

CONSTANT RADIUS VERSION

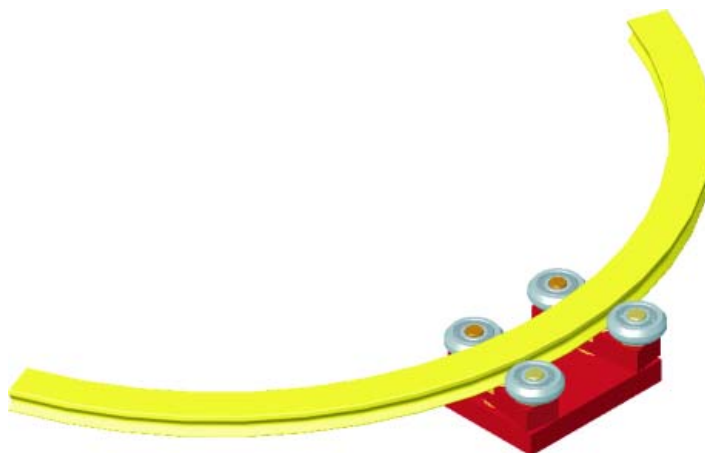

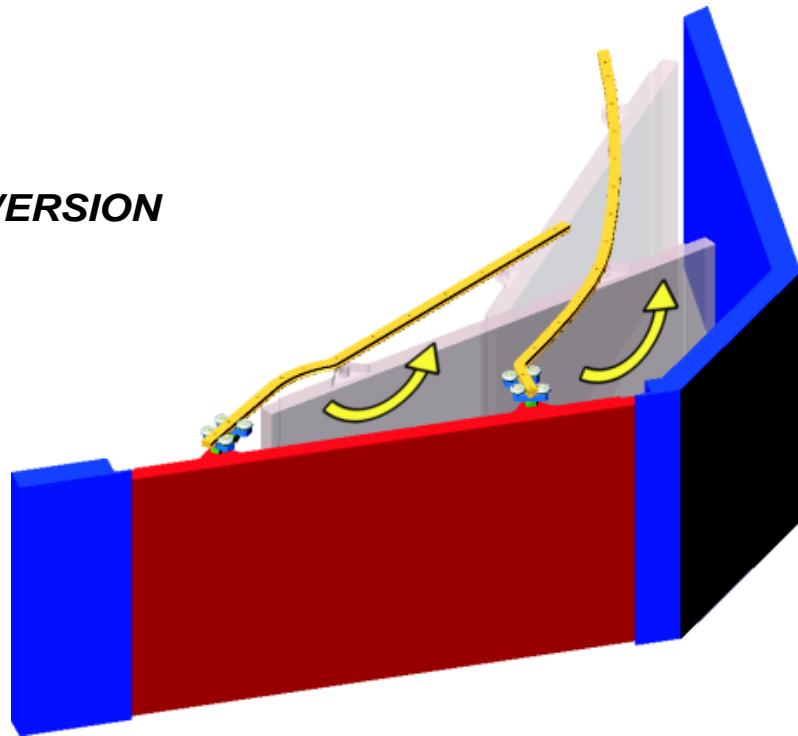
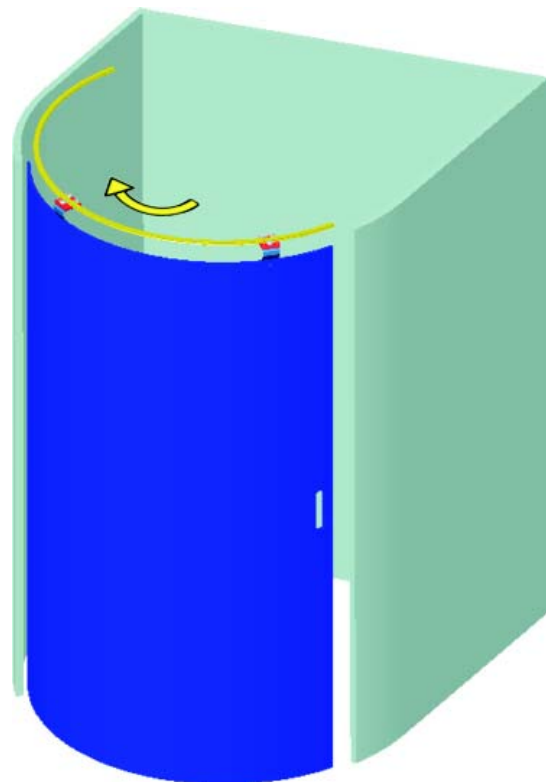
APPLICATION EXAMPLES:**VARIABLE RADIUS VERSION***(Rail + Slider)***CONSTANT RADIUS VERSION***(Rail + Slider)***APPLICATION FIELDS:**

- Packaging machinery
- Train manufacturing and rebuilding (internal and external doors)
- Naval construction (internal doors)
- Food industry

MOUNTED RAIL / SLIDER

(Variable Radius Version)

TECHNICAL DATA

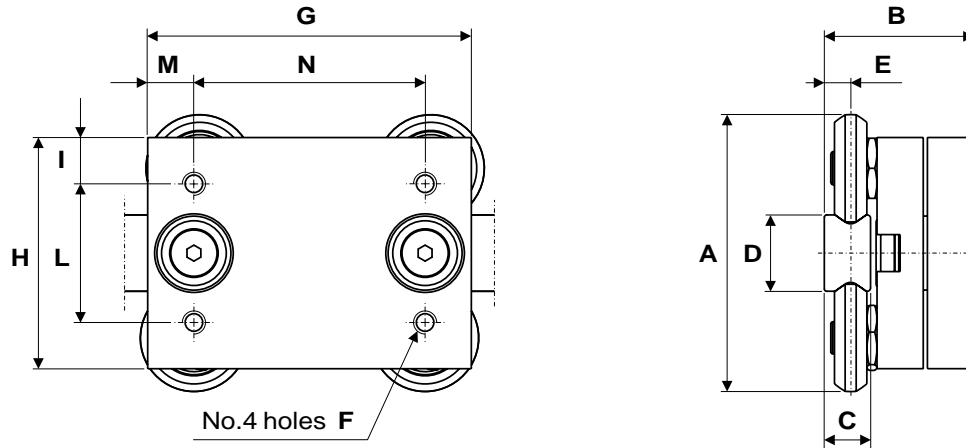

Type	A	B	C	D	E	F	G	H	I	L	M	N	Weight	
													Rail [kg/m]	Slider [kg]
CCT08 + GCT01	60	32.3	10	16.5	5.7	M5	70	50	10	30	10	50	1.1	0.4
CCT11 + GCT05	89.5	36.4	13.5	23	7.5	M8	100	80	12.5	55	10	80	2.1	1.1

NOTES:

- Radius and type of curve upon request
- Fixing holes (rail GCT01/GCT05): M6, pitch: 80 mm (other kind of drilling/holes upon request)
- Fixing holes position: mark your structure using the rail as template
- Rail and Slider protected with zinc plating (ISO2081)
- Maximum stroke for one rail: 3170 mm (for CCT08), 3140 mm (for CCT11)
- Maximum developed length for one rail: 3240 mm
- Joined curved rails are not recommended

Order Codes:

SLIDER: **CCT08** RAIL: **GCT01***
CCT11 **GCT05***

* the following data must be specified on the customer's drawing: radius, type of curves, etc.

LOAD CAPACITIES

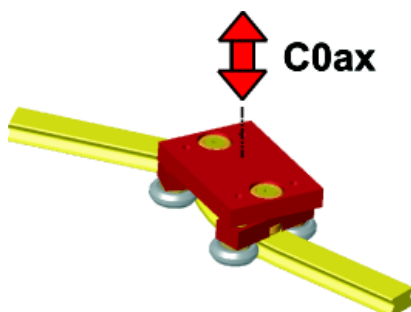

Type	C _{0ax} [N]
CCT08 - GCT01	400
CCT11 - GCT05	1130

For more information and assistance, please contact our engineering department.

MOUNTED RAIL / SLIDER

(Constant Radius Version)

TECHNICAL DATA

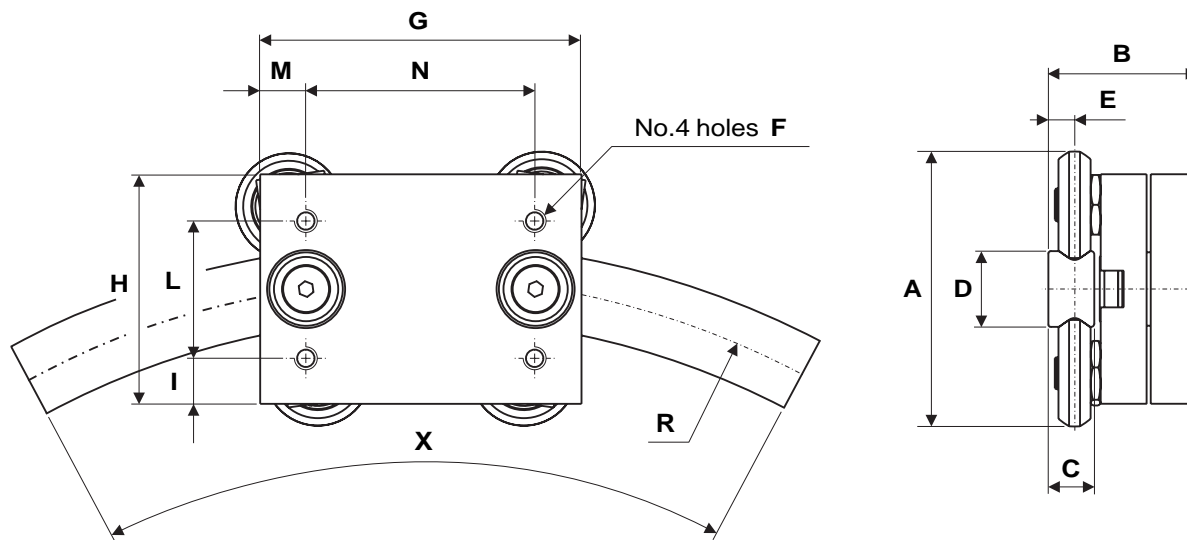

Type	A	B	C	D	E	F	G	H	I	L	M	N	Weight	
													Rail [kg/m]	Slider [kg]
CCT08 + GCT01	60	32.3	10	16.5	5.7	M5	70	50	10	30	10	50	1.1	0.4
CCT11 + GCT05	89.5	36.4	13.5	23	7.5	M8	100	80	12.5	55	10	80	2.1	1.1

NOTES:

- Radius (R) and Angle (X) upon request (minimum R = 120 mm)
- Fixing holes (rail GCT01/GCT05): M6, pitch: 80 mm (other kind of drilling/holes upon request)
- Fixing holes position: mark your structure using the rail as template
- Rail and Slider protected with zinc plating (ISO2081)
- Maximum stroke for one rail: 3170 mm (for CCT08), 3140 mm (for CCT11)
- Maximum developed length for one rail: 3240 mm
- Joined curved rails are not recommended

Order Codes:

SLIDER: **CCT08** RAIL: **GCT01***
CCT11 **GCT05***

* radius (R) and angle (X) to be specified

LOAD CAPACITIES

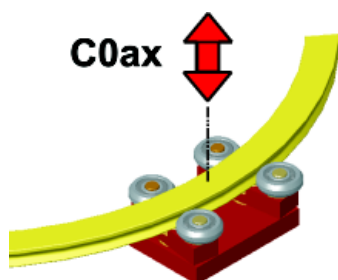

Type	C _{0ax} [N]
CCT08 - GCT01	400
CCT11 - GCT05	1130

For more information and assistance, please contact our engineering department.