

INSTRUMENT APPROACH CHART-ICAO

VAR3° W

AERODROME ELEV 16m
THR RWY22 ELEV 5.5m

ATIS 126.65
APP 120.65(123.05)
TWR 118.35(130.0)

ZGOW JIEYANG/Chaoshan
ILS/DME y RWY22

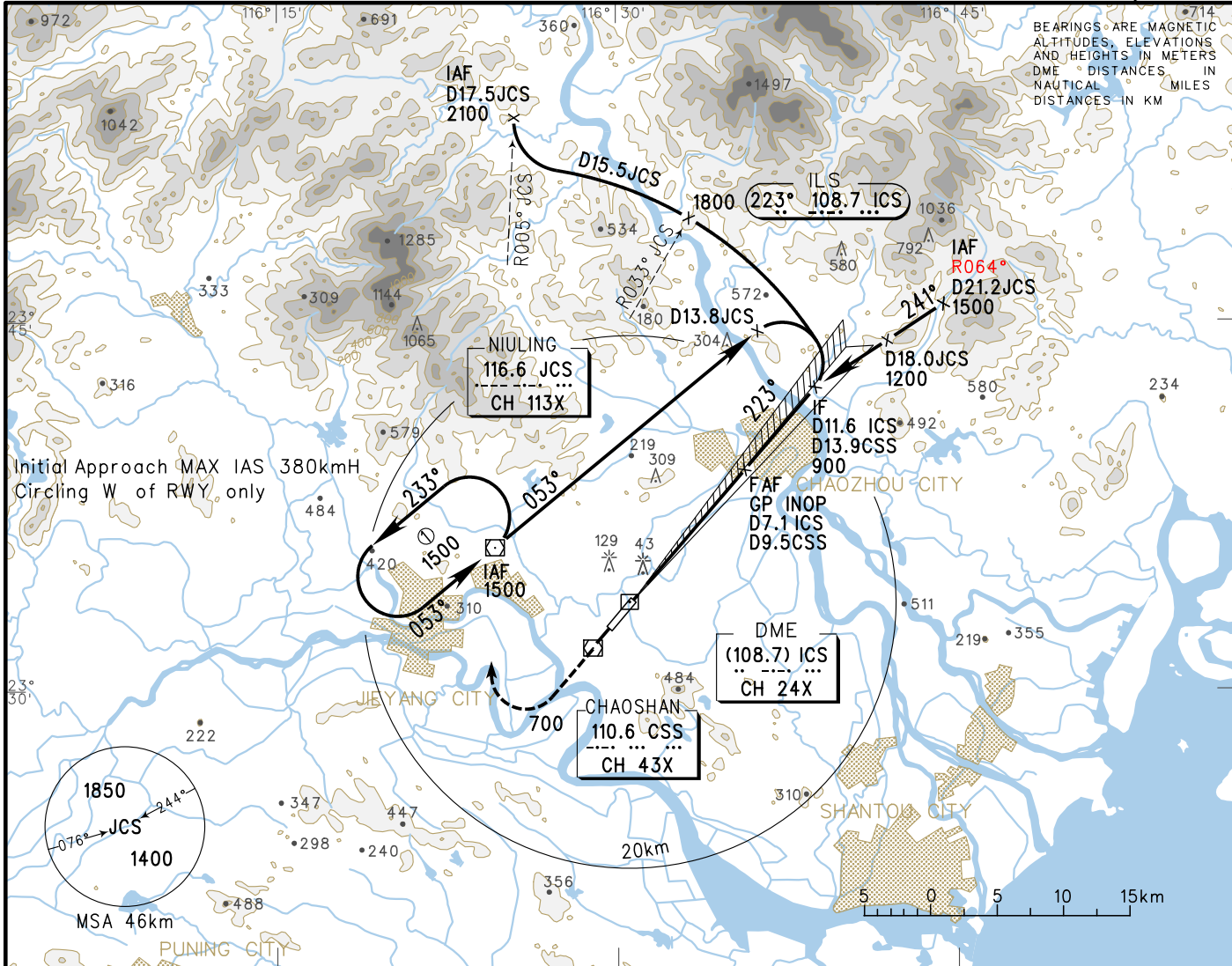

GP INOP	DME (ICS) (NM)	2	3	4	5	6	7		
	ALT (m)	199	296	393	490	587	684		

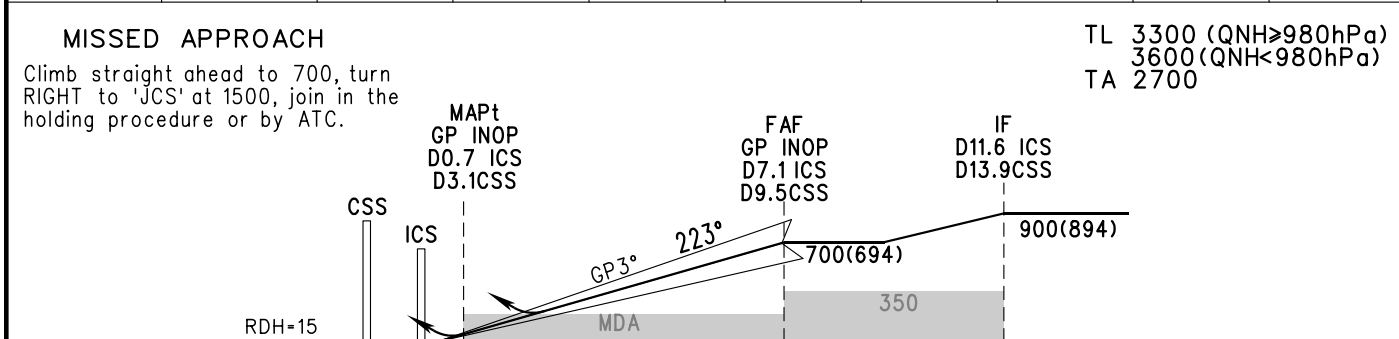

	A	B	C	D	FAF-MAPt(GP INOP) 11.9km							
ILS/DME DA(H) RVR/VIS		66(60) 550/800			GS in kt	80	100	120	140	160	180	
					kmH	150	185	220	260	295	335	
GP INOP MDA(H) VIS		195(190) 2800			Time min:sec	4:49	3:51	3:13	2:45	2:25	2:09	
CIRCLING MDA(H) VIS	220(205) 3200		385(370) 4400	445(430) 5000	Rate of descent m/s	2.2	2.7	3.2	3.8	4.3	4.9	

Changes: Add radial of approach transition.